

ODER

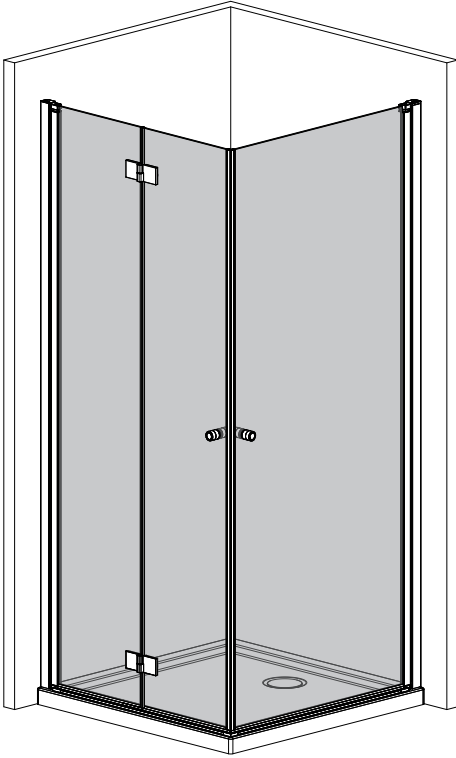

K-1FTG+K-1PTG

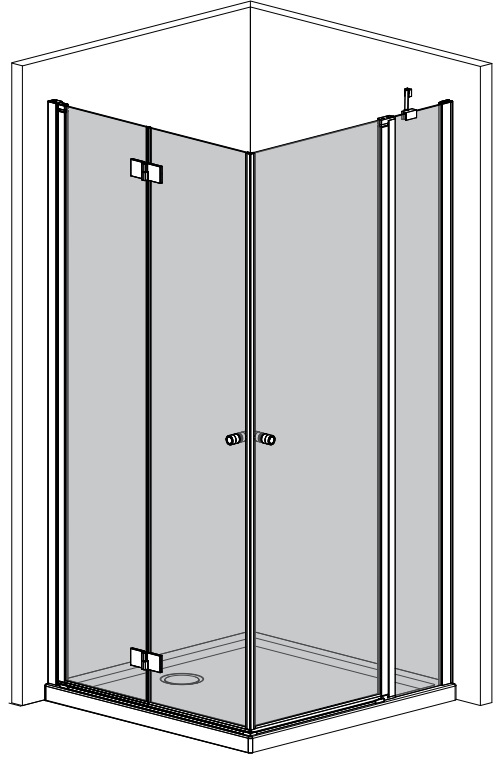

K-1FTG+K-1PTG1F



Montageanleitung



Assembly instruction

ODER K-1FTG+K-1PTG



ODER K-1FTG+K-1PTG1F



1.A

Montage auf Duschwanne

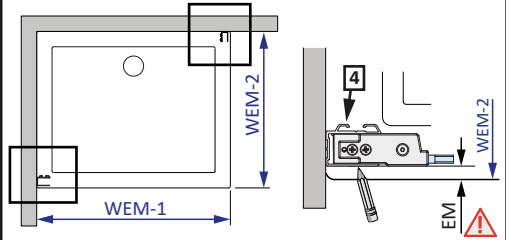

Wanne unter den Fliesen!

EM = 18 mm

Typ	WEM-1 WEM-2
900	885-900
1000	985-1000

Wanne vor den Fliesen!

EM = 28 mm

Typ	WEM-1 WEM-2
900	895-910
1000	995-1010

1.B

bodenebene Montage

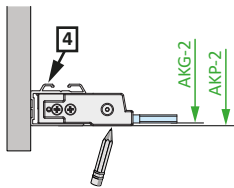
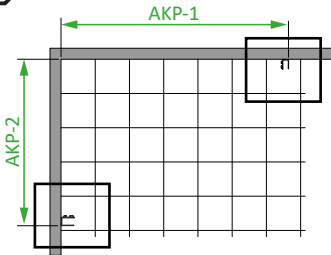

AKG-1/AKG-2
AKP-1/AKP-2

→ Karte mit Abmessungen

2

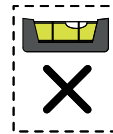
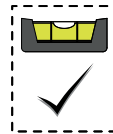
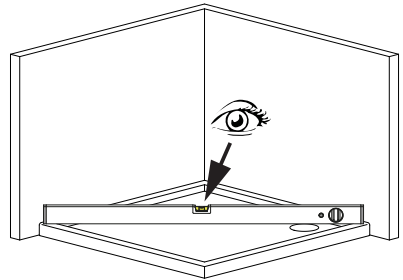



2.1

2.2

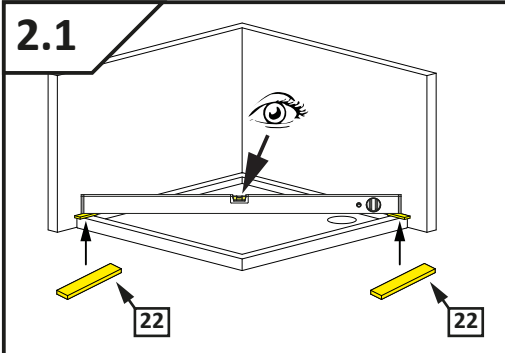
2.1



Montage mit Schwallschutzleiste  2mm
Installation with threshold profile

Montage ohne Schwallschutzleiste  1mm
Installation without threshold profile

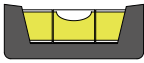



OK

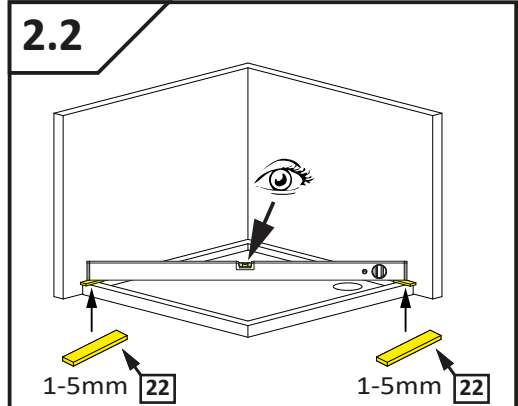

2.2



1-5mm  22

1-5mm  22

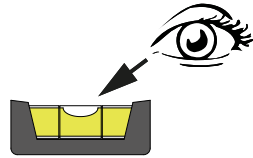

OK



3

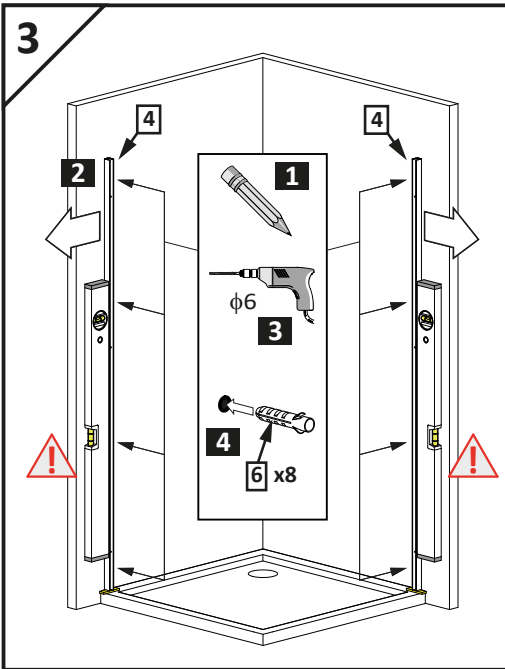

4

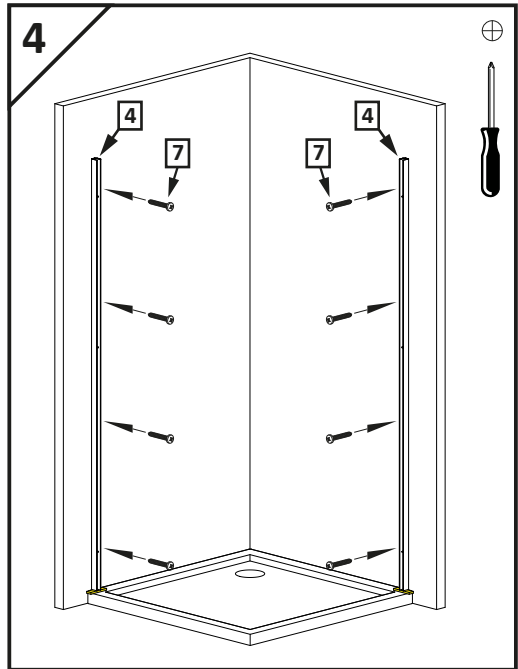

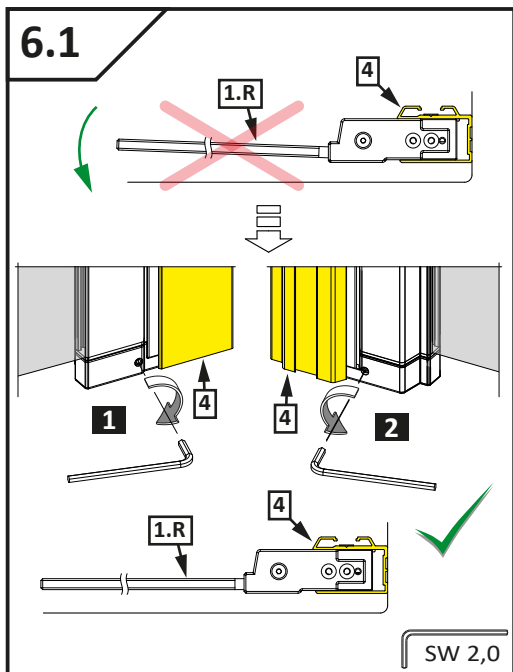
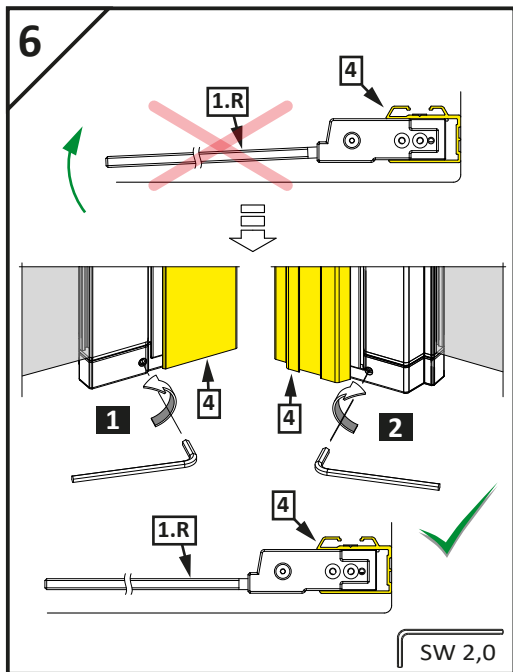
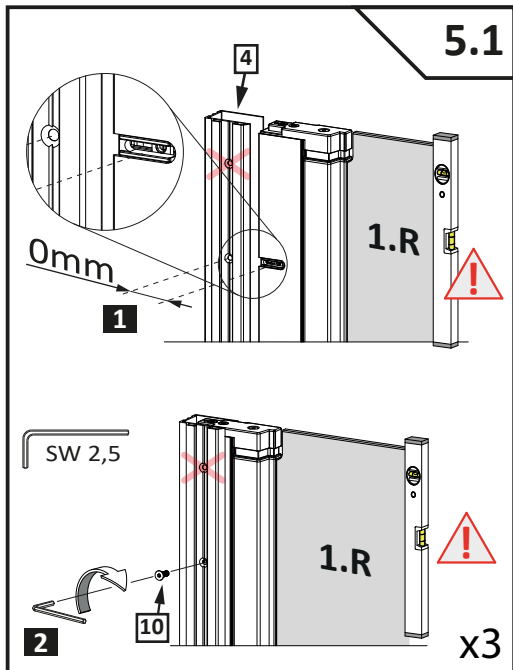
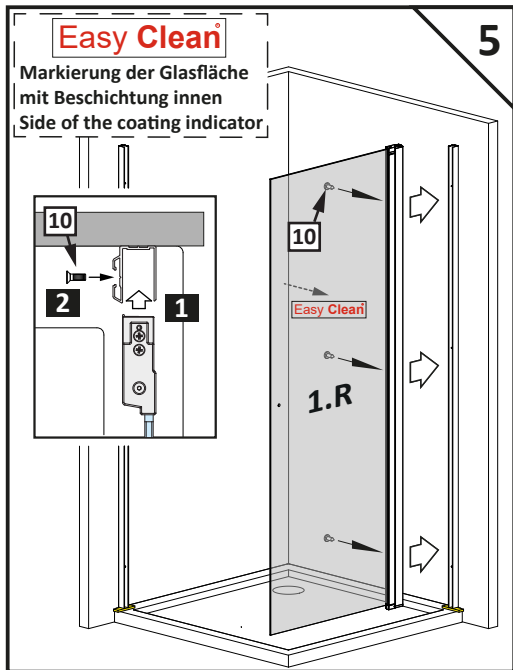

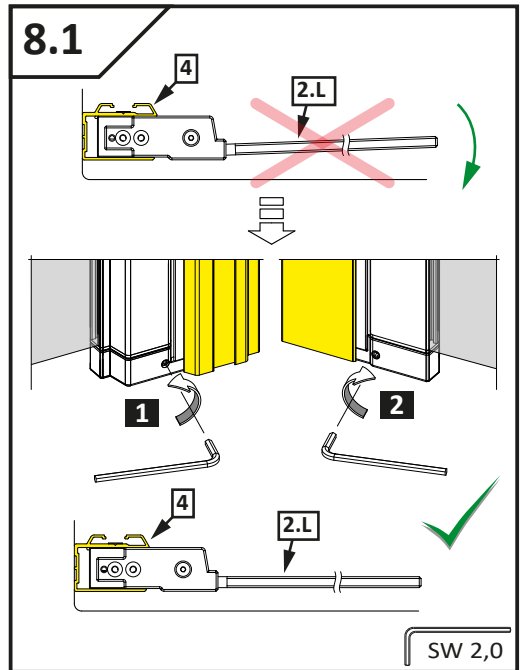
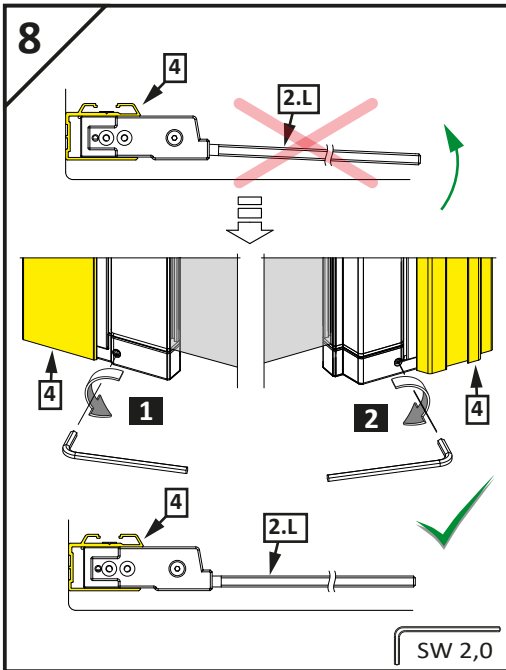
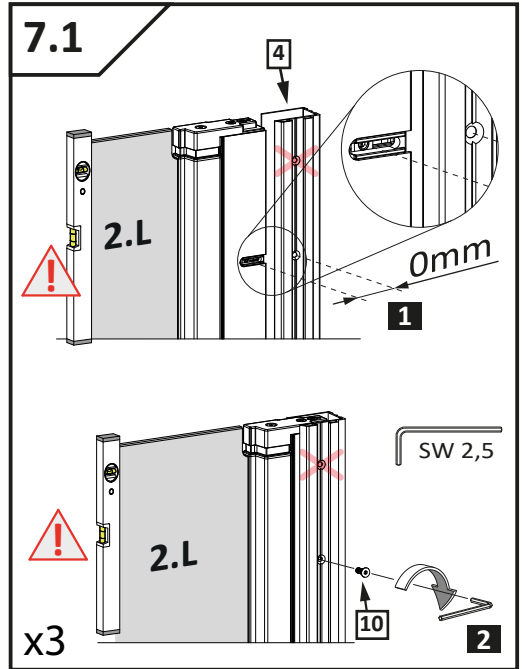
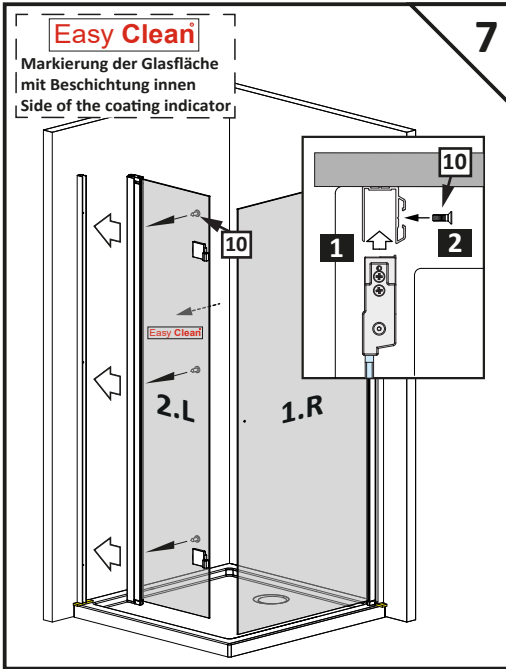

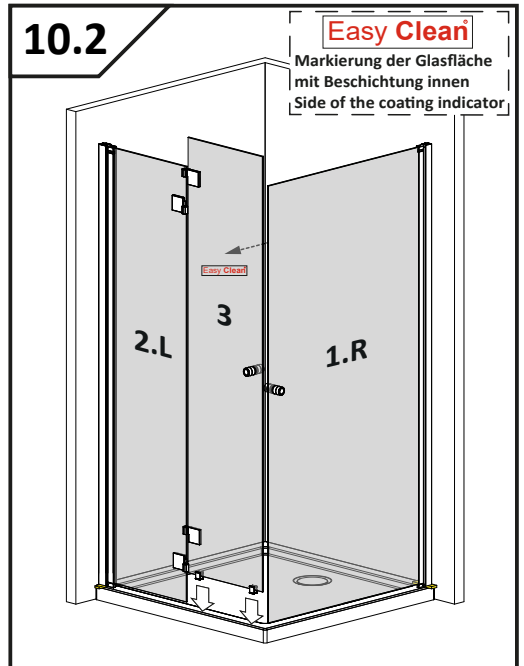
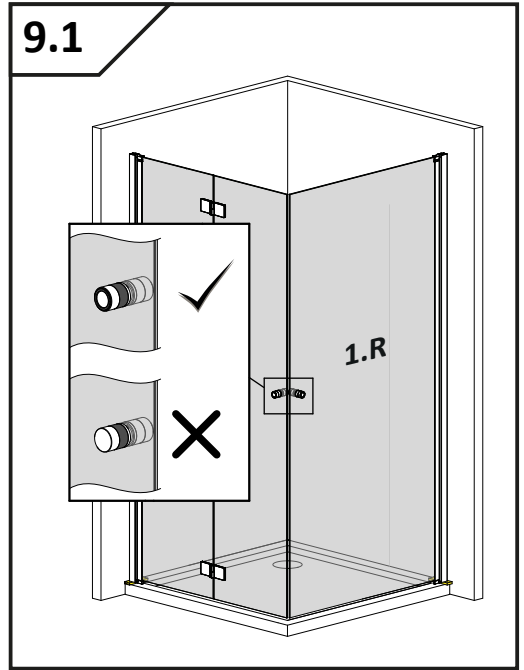
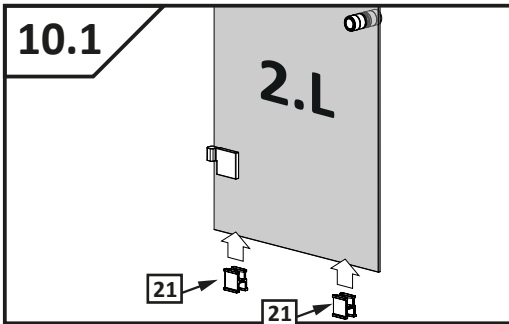
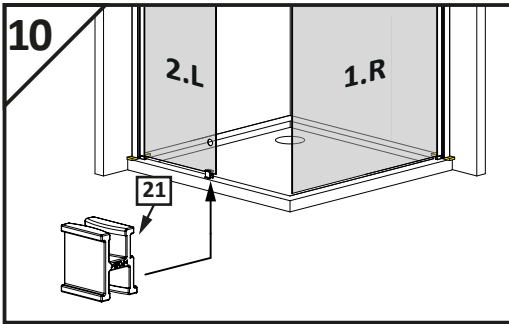
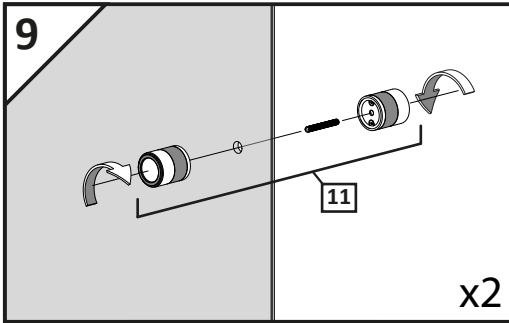

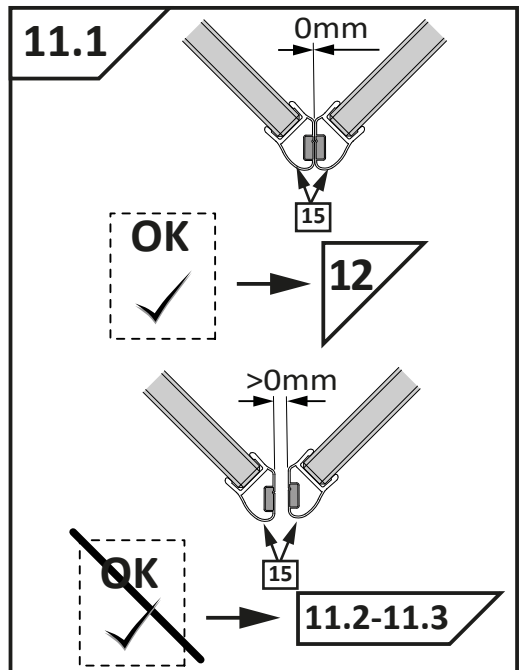
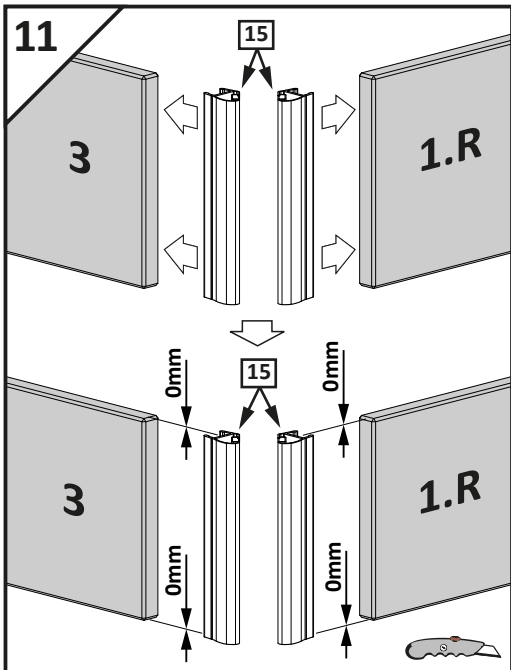
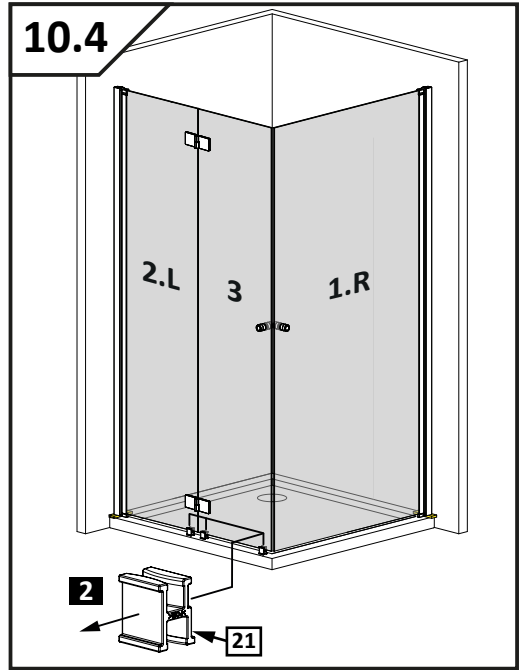
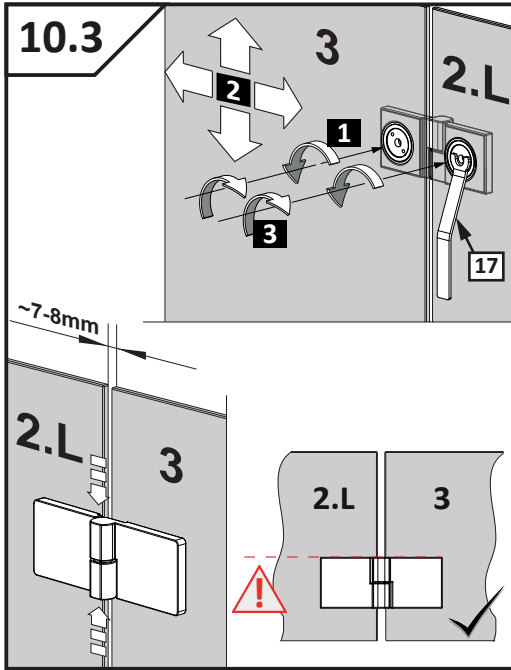

11.2

SW 2,5

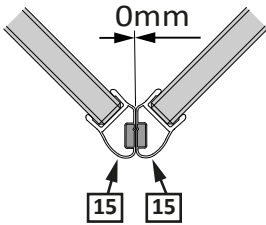
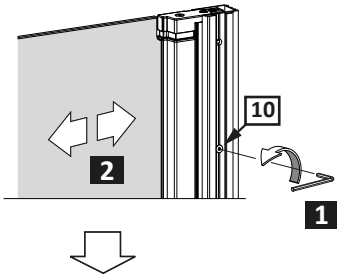

OK

11.3

SW 2,5

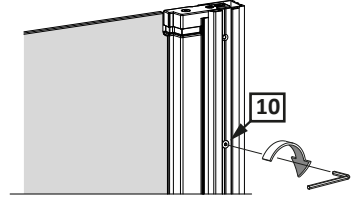

12

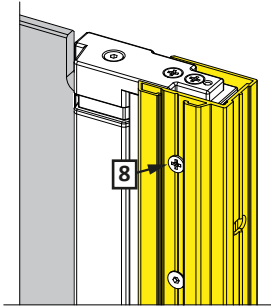
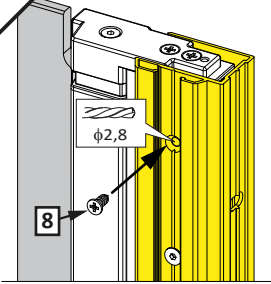
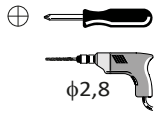

OK

x2

12.1

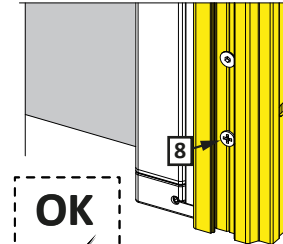
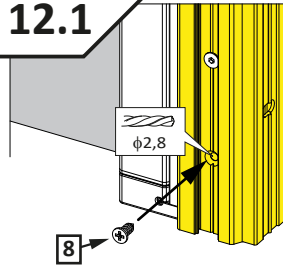
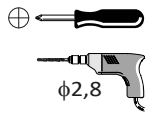

OK

x2

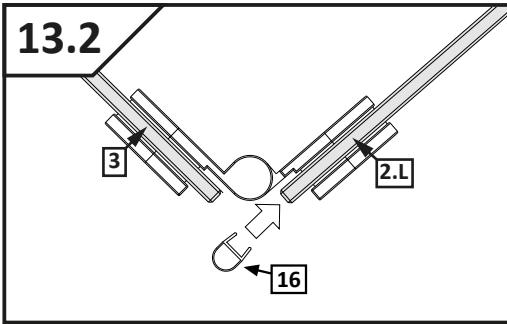
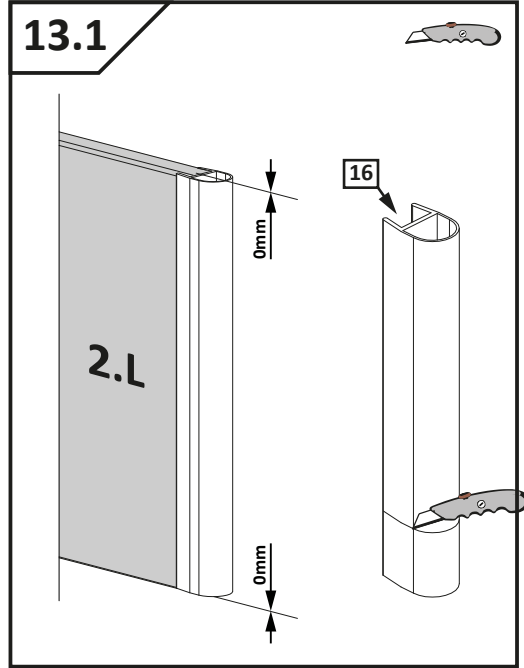
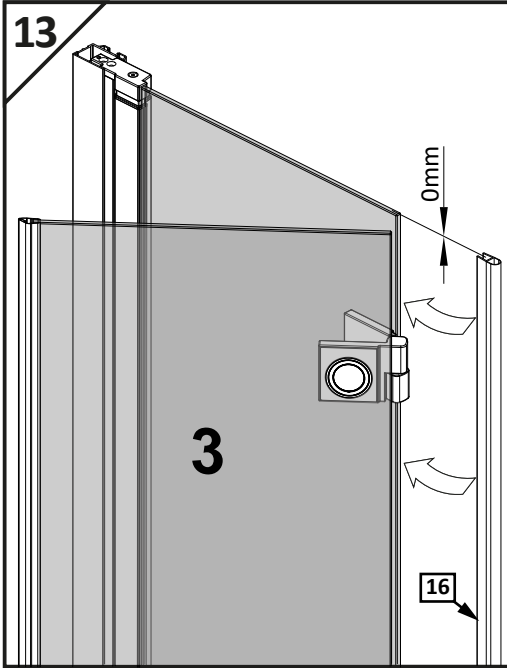

Montage mit Schwallenschutzleiste
Installation with threshold profile

→ **14.1**

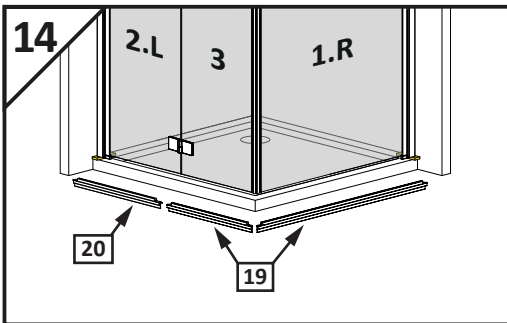

Montage ohne Schwallenschutzleiste
Installation without threshold profile

→ **14.2**

14.1

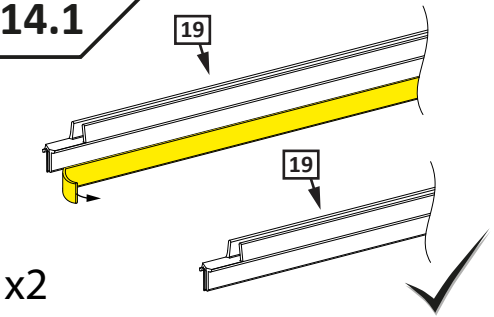

14.2

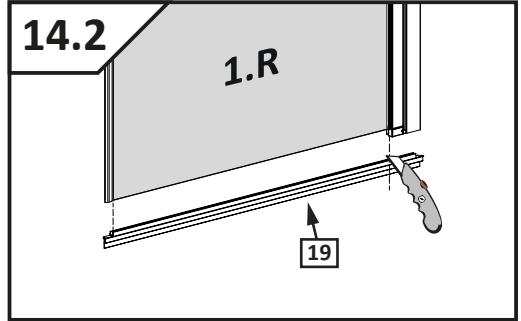

14.3

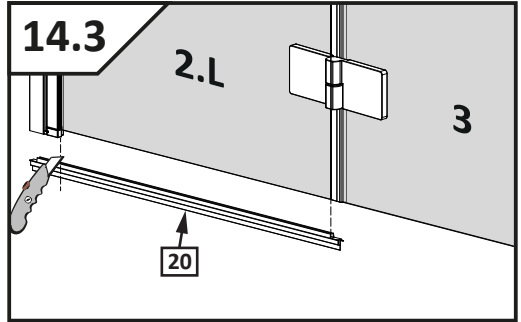

14.4

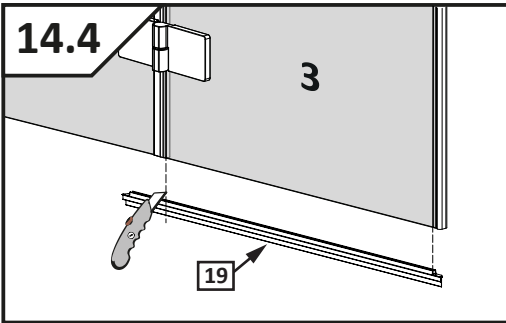

14.5

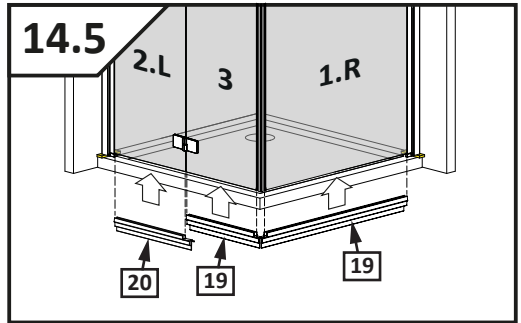

Montage mit Schwallenschutzleiste
Installation with threshold profile



15

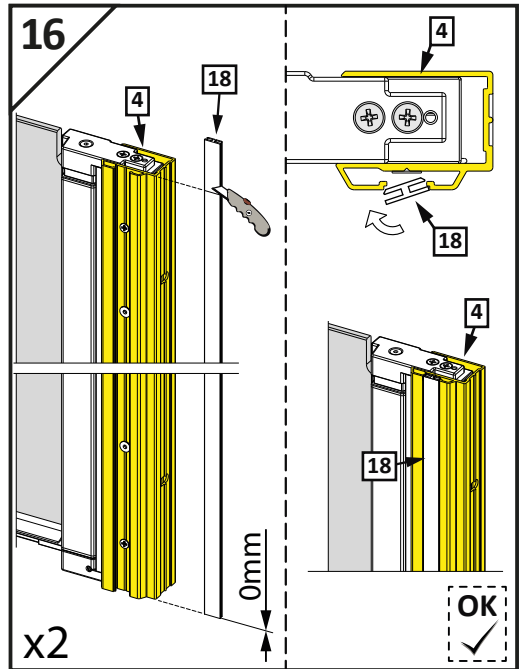
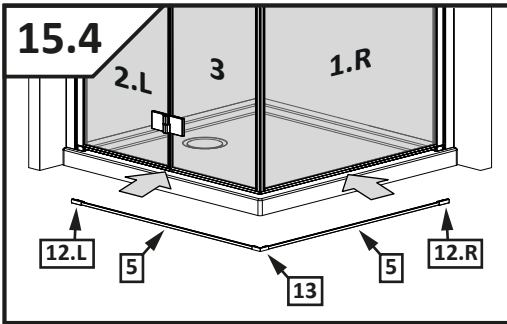
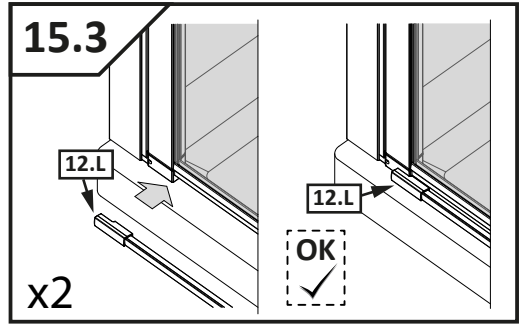
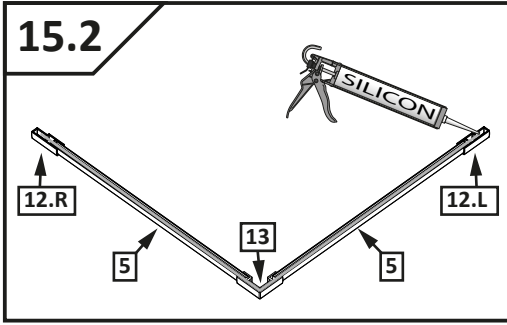
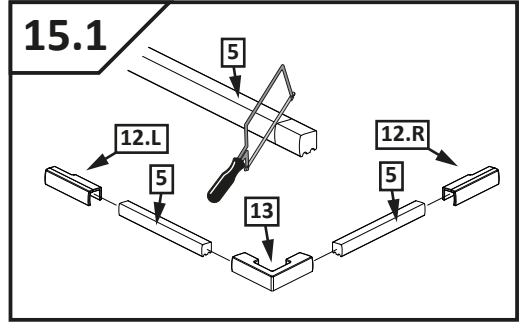
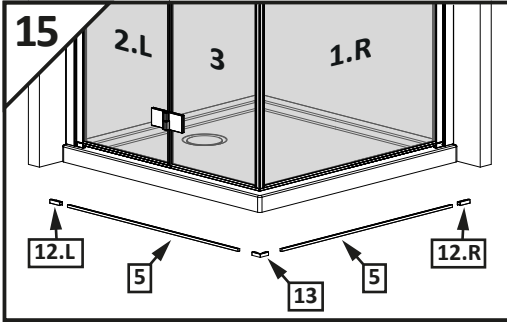

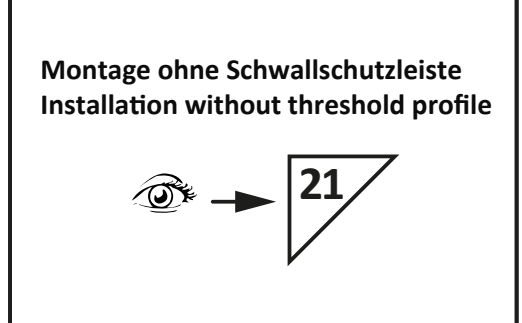
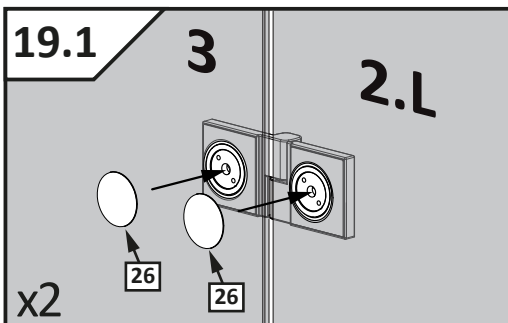
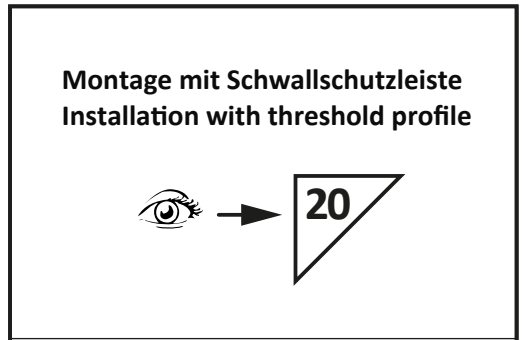
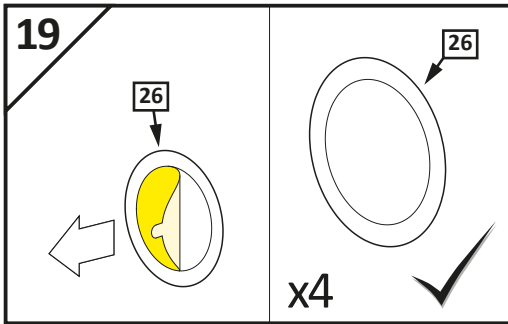
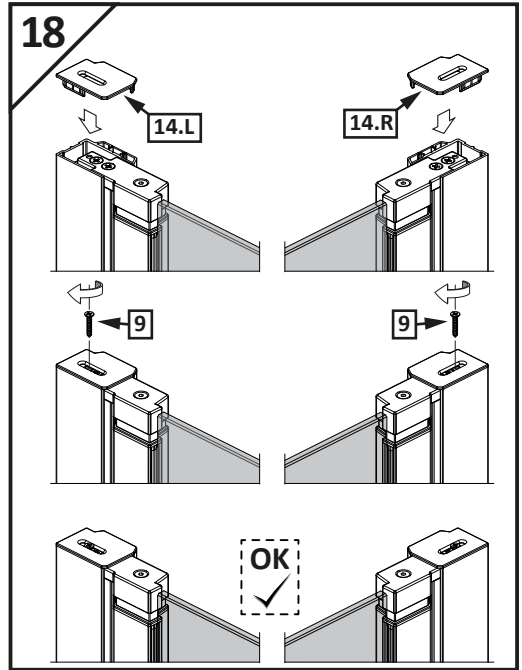
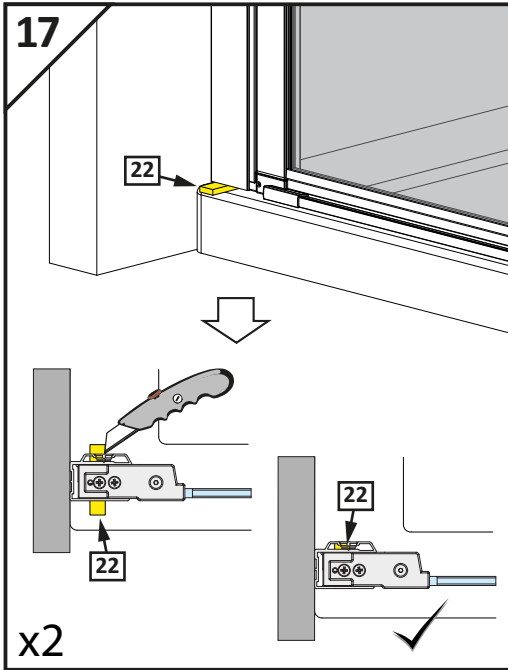

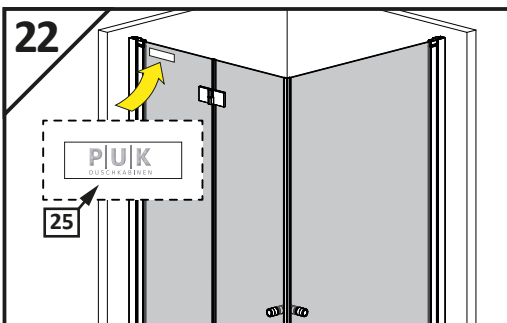
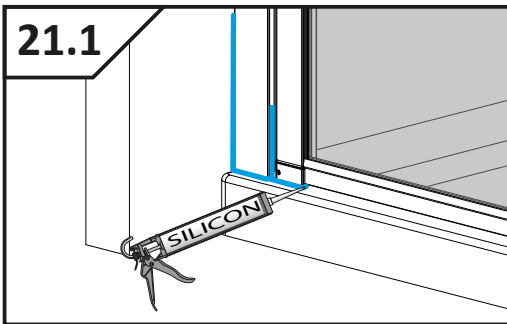
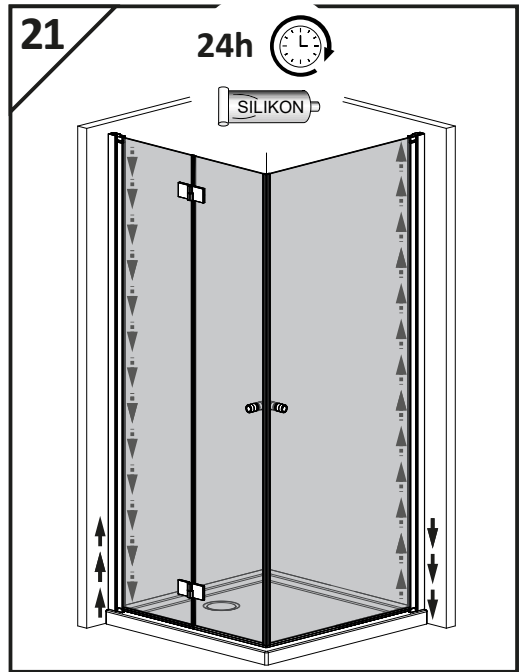
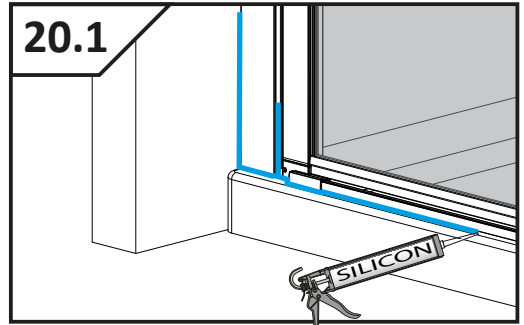
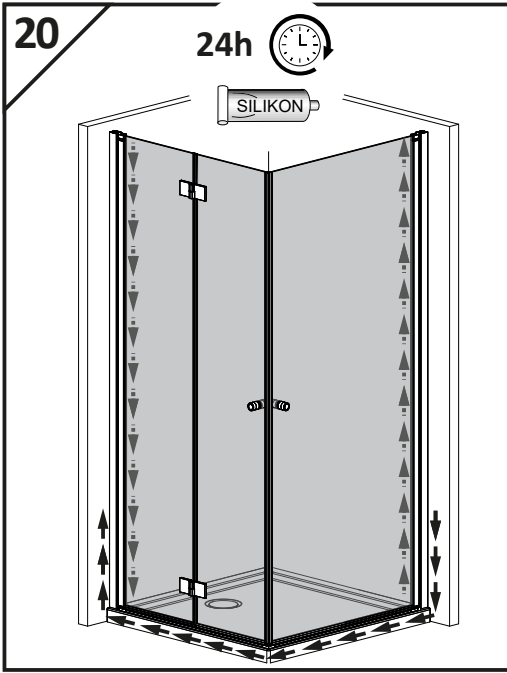







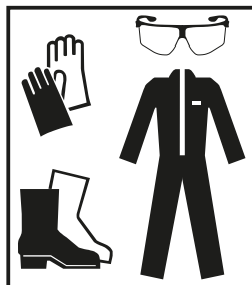
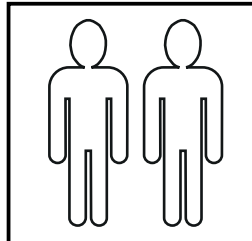
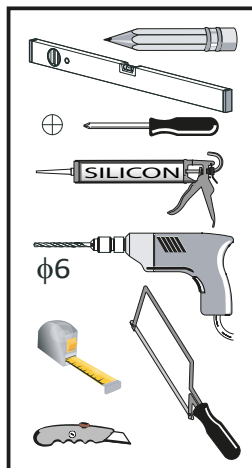

ODER K-1FTG+K-1PTG

No. Nr.	Bezeichnung Mark	Stück Pcs.
1.R 2.L 3.		1 1 1
4.		2
5.		2
6.	φ6	8
7.	4.8x40 DIN 7981	8
8.	3.5x13 DIN 7982	4
9.	2.9x13 DIN 7982	2
10.	M4x10 DIN 7991	6
11.		2
12.L 12.R		1 1
13.		1
14.L 14.R		1 1
15.		2
16.		1
17.		1
18.		2
19.		2
20.		1

Montage mit Schwallenschutzleiste
Installation with threshold profile



No. Nr.	Bezeichnung Mark	Stück Pcs.
21.		3
22.	 1mm 2mm 3mm 4mm 5mm	4
23.1	 SW 2,0	1
23.2	 SW 2,5	1
24.	 ϕ 2,8	1
25.		1
26.		4

ODER K-1FTG+K-1PTG

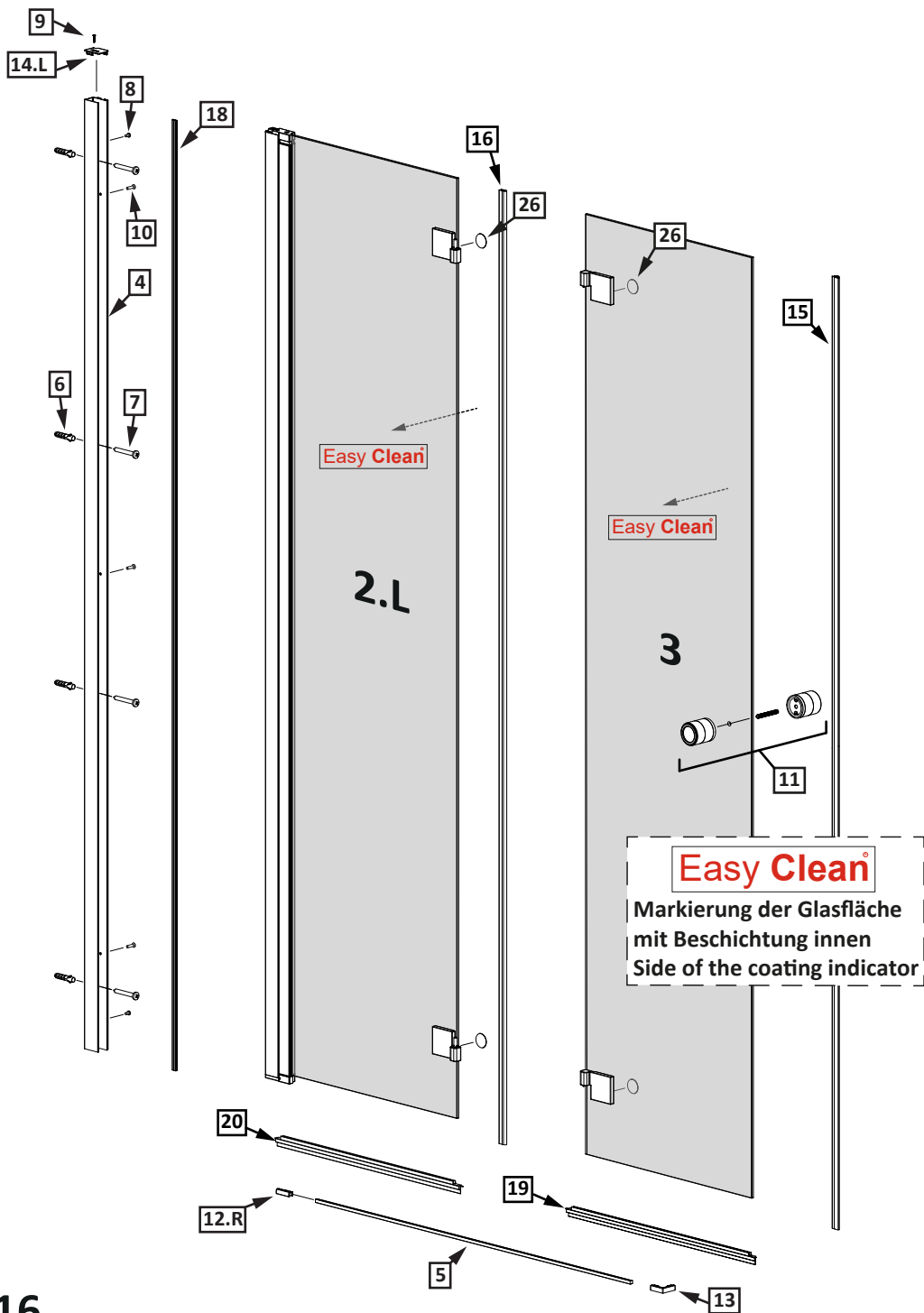

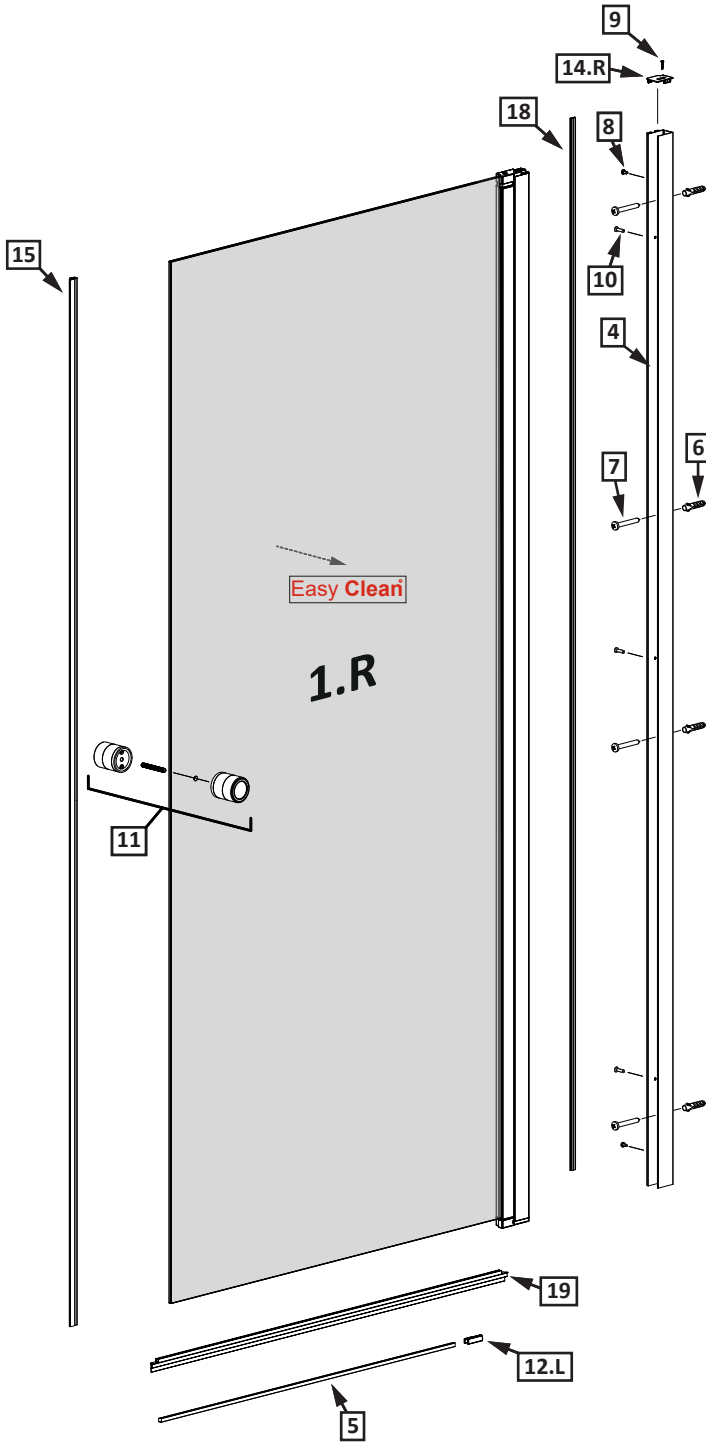

23

Montage auf Duschwanne

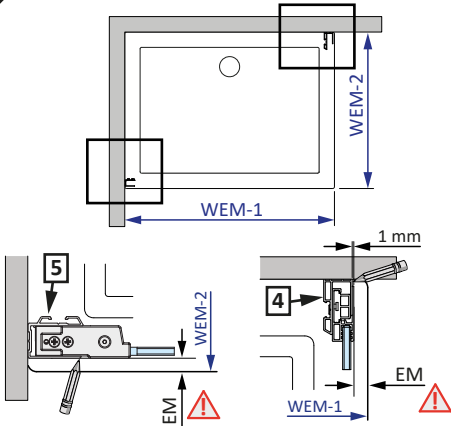

Wanne unter den Fliesen!

EM = 18 mm

Typ	WEM-1	WEM-2
900	885-900	
1000	985-1000	

Wanne vor den Fliesen!

EM = 28 mm

Typ	WEM-1	WEM-2
900	895-910	
1000	995-1010	

bodenebene Montage

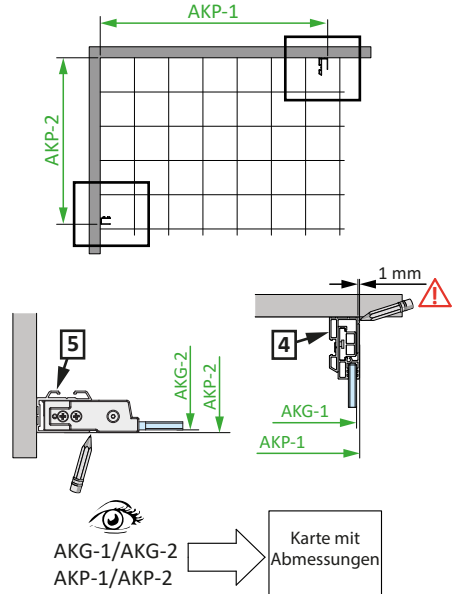

24

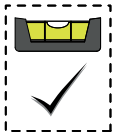
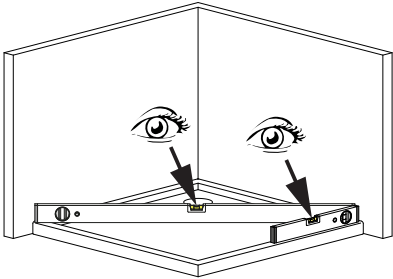

24.1

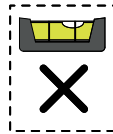

24.2

24.1

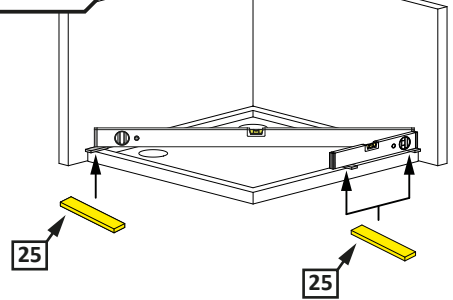

Montage mit Schwallenschutzleiste
Installation with threshold profile



Montage ohne Schwallenschutzleiste
Installation without threshold profile

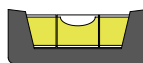

OK



24.2

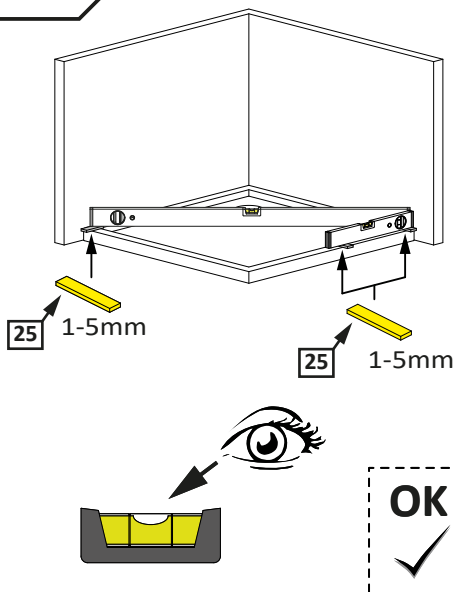

25

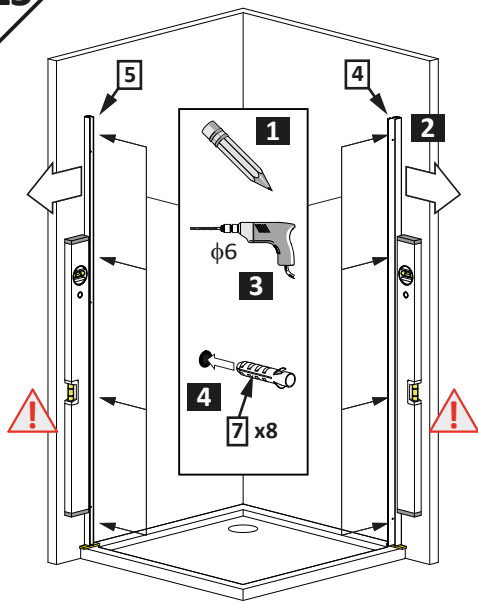

26

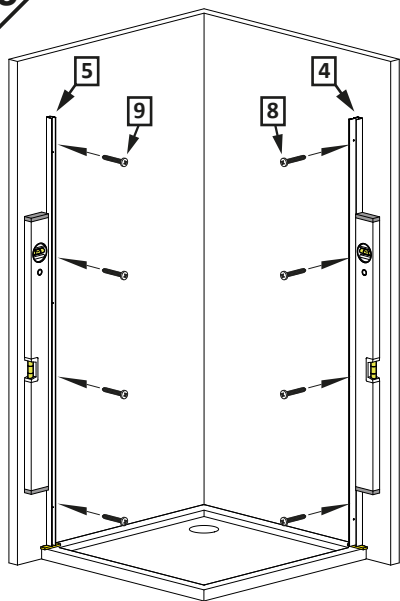

27

Easy Clean
 Markierung der Glasfläche
 mit Beschichtung innen
 Side of the coating indicator

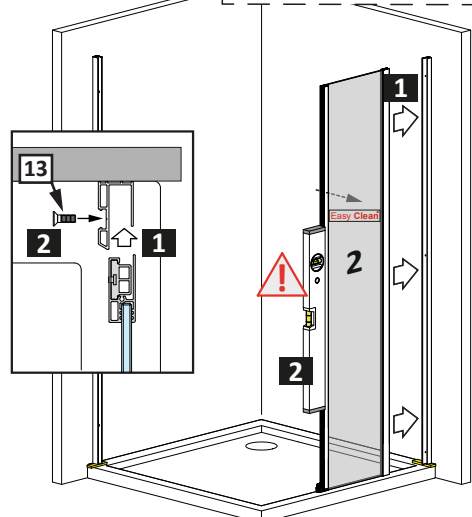

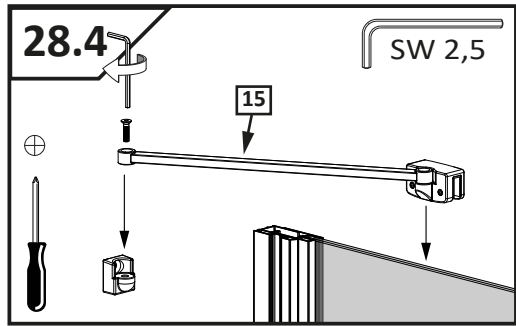
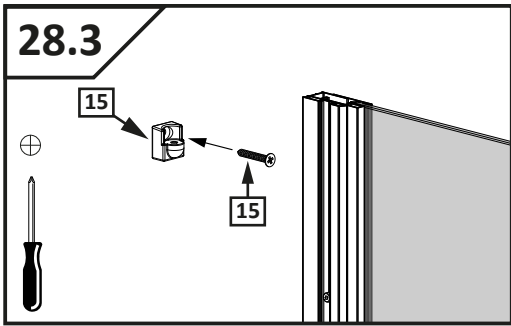
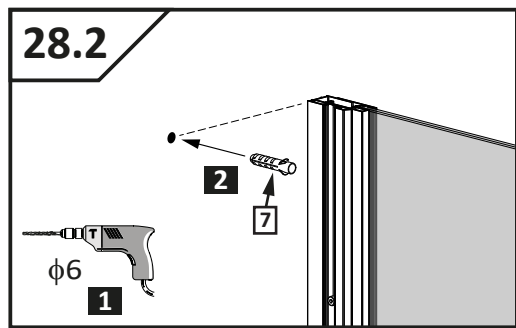
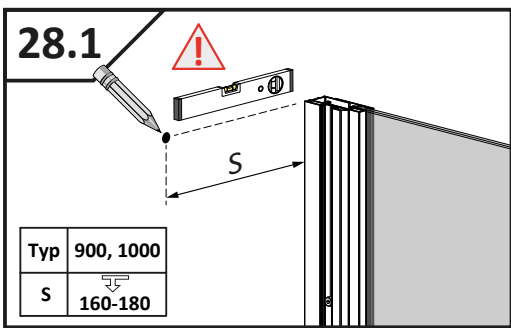
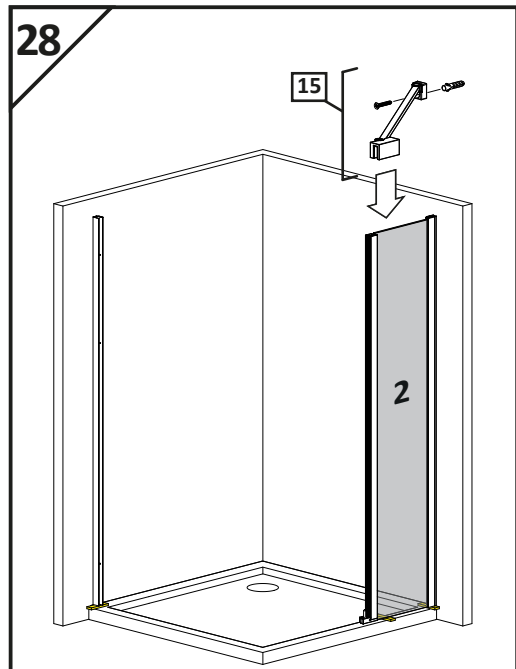
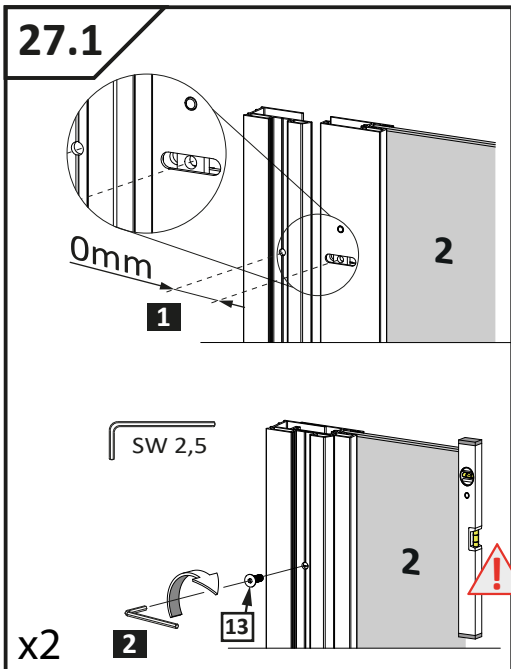

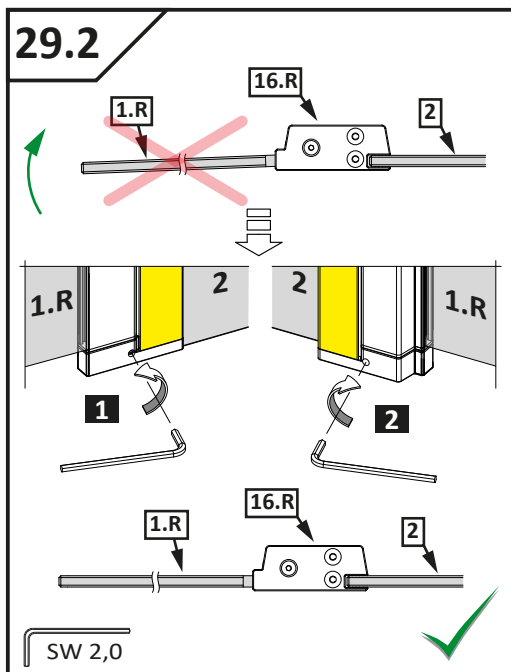
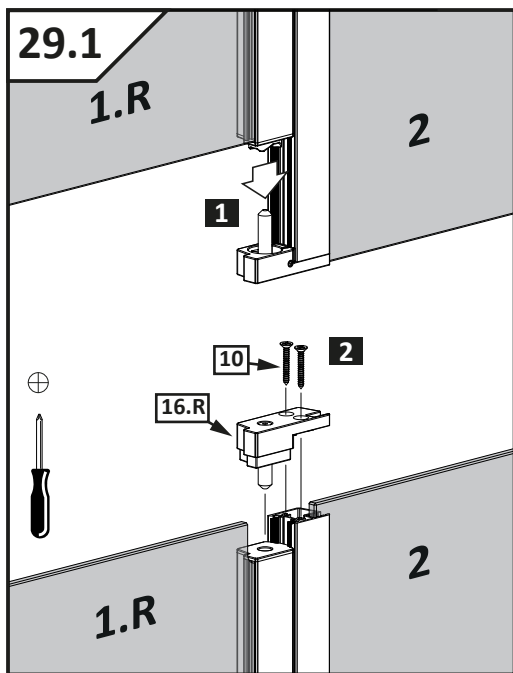
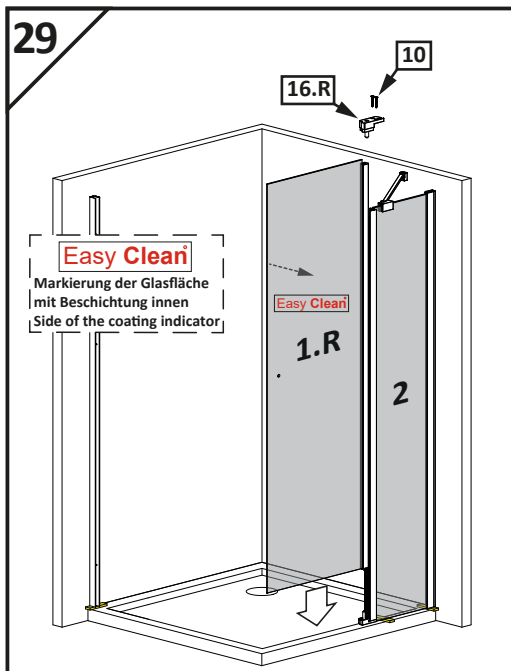
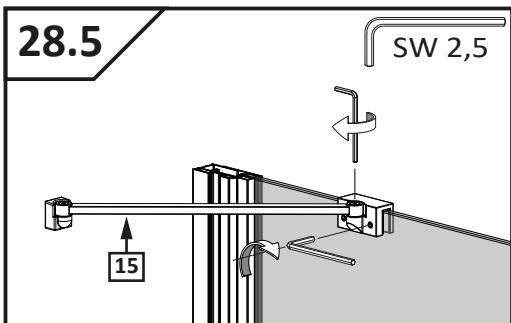

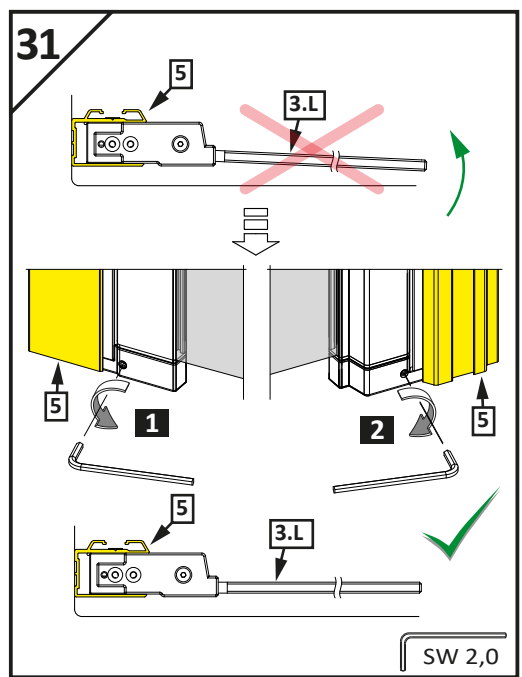
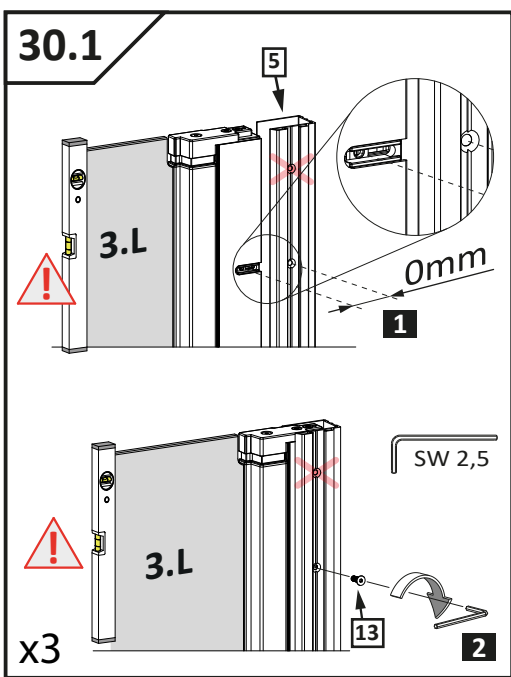
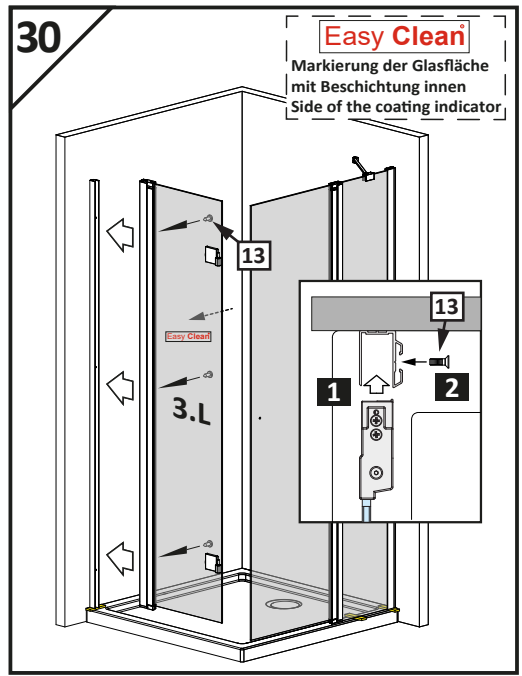
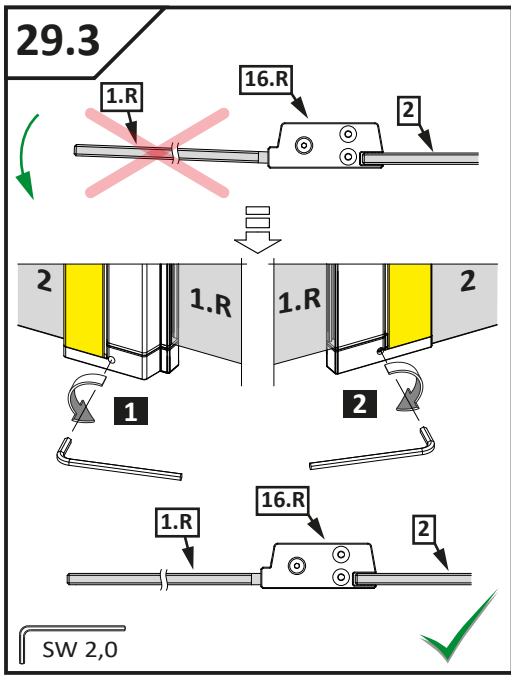

31.1

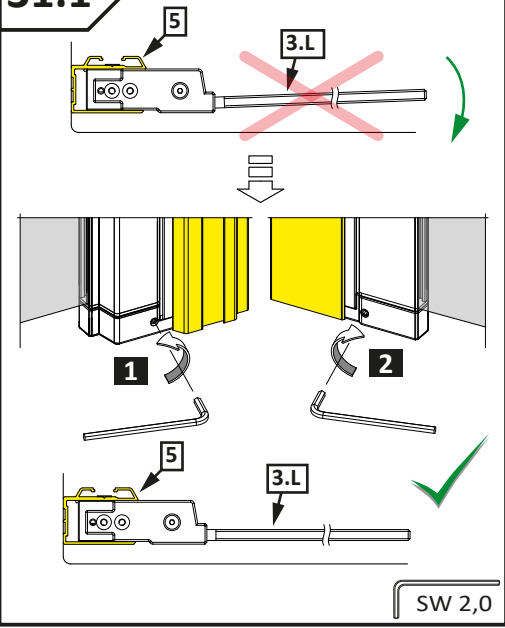

32

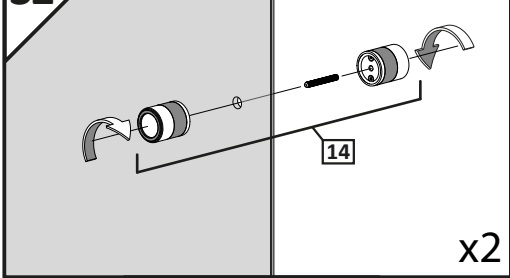

32.1

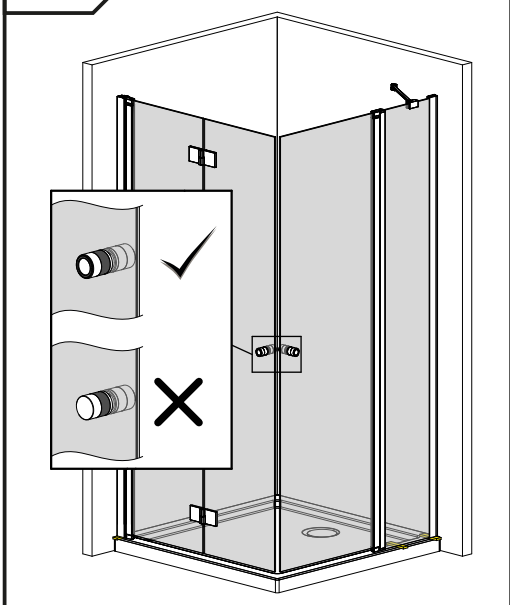

33

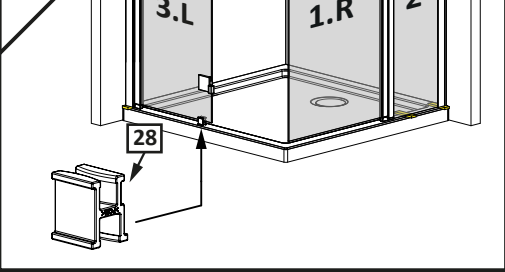

33.1

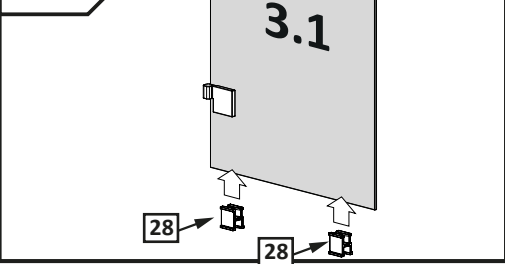

33.2

Easy Clean

Markierung der Glasfläche
mit Beschichtung innen
Side of the coating indicator

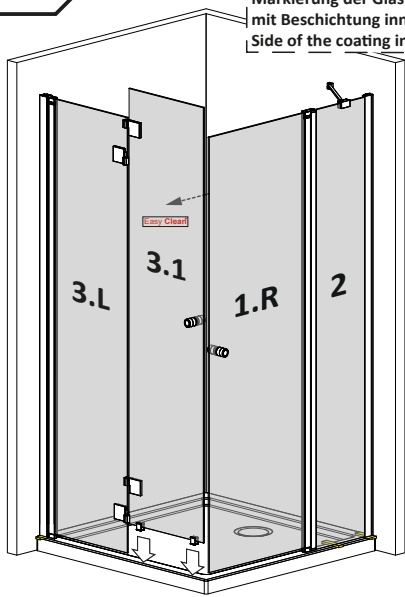

33.3

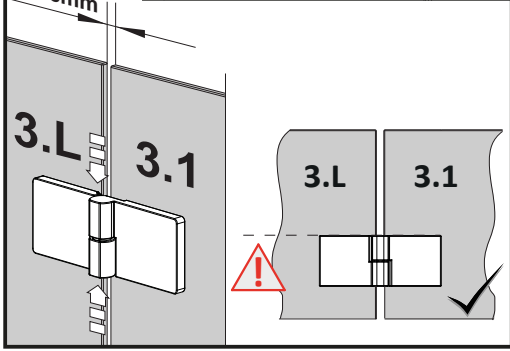
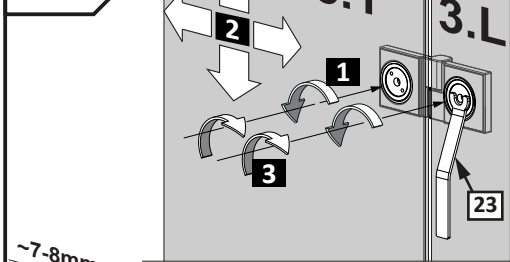

33.4

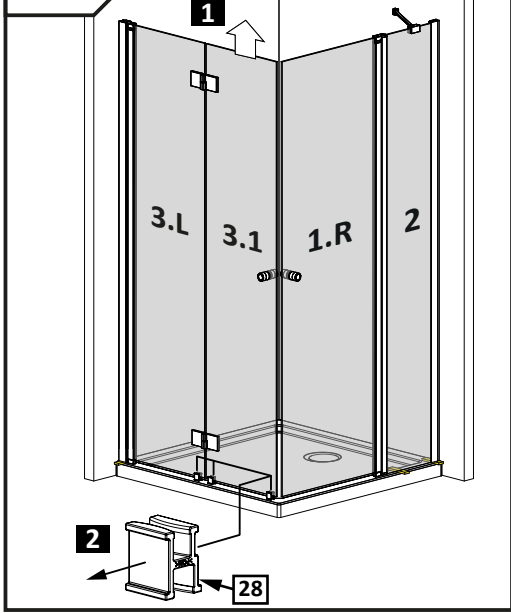

34

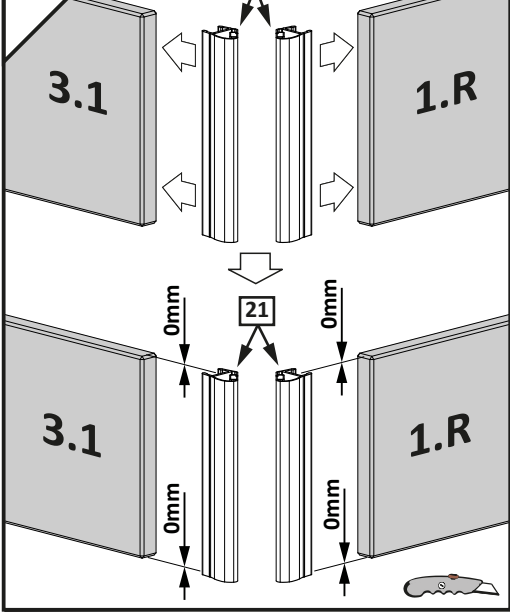

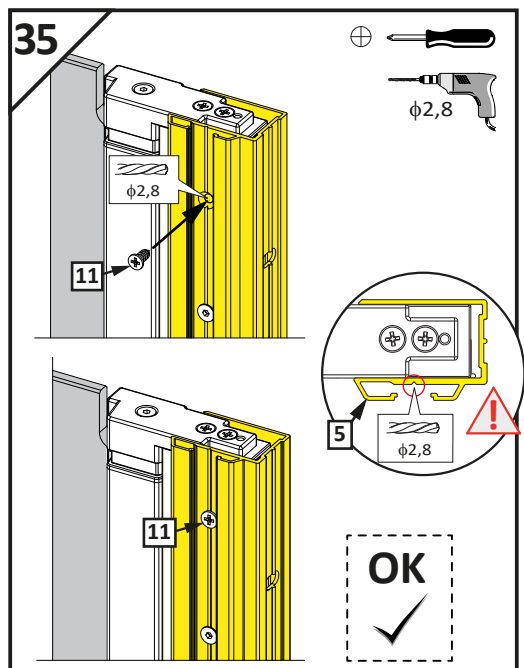
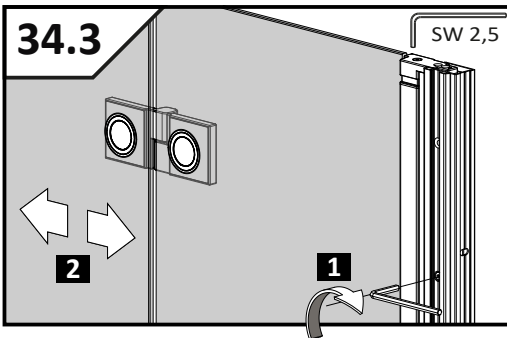
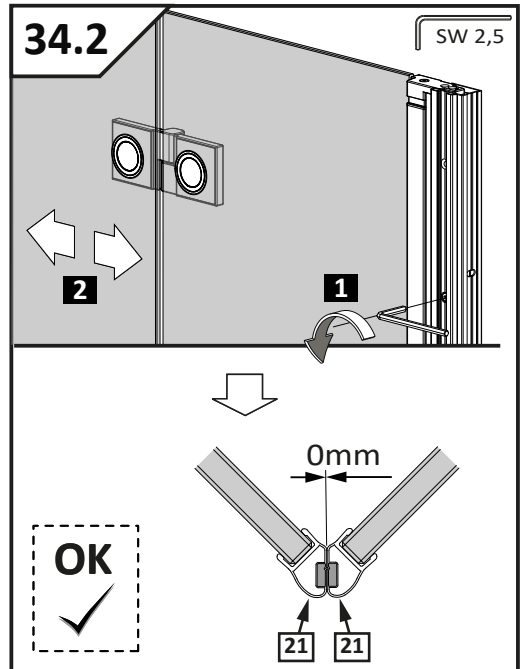
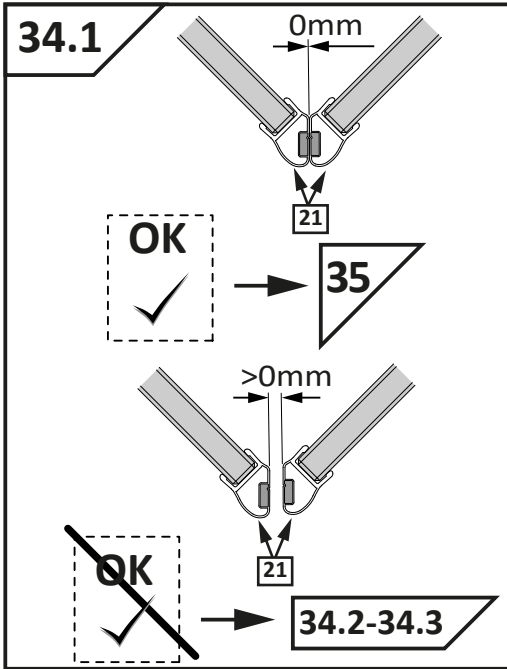

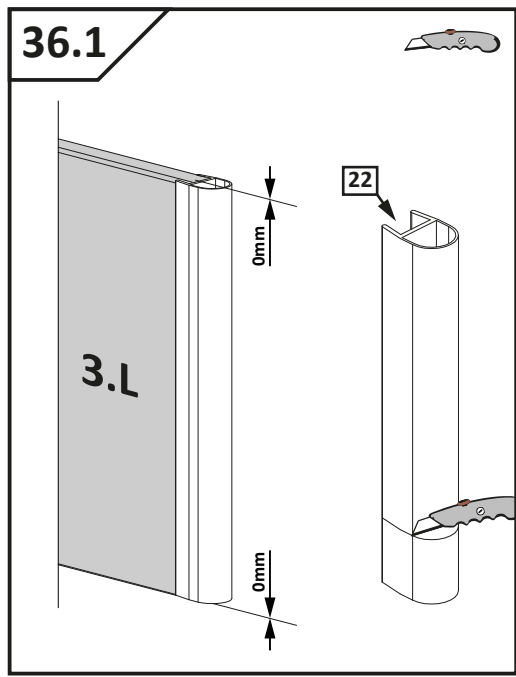
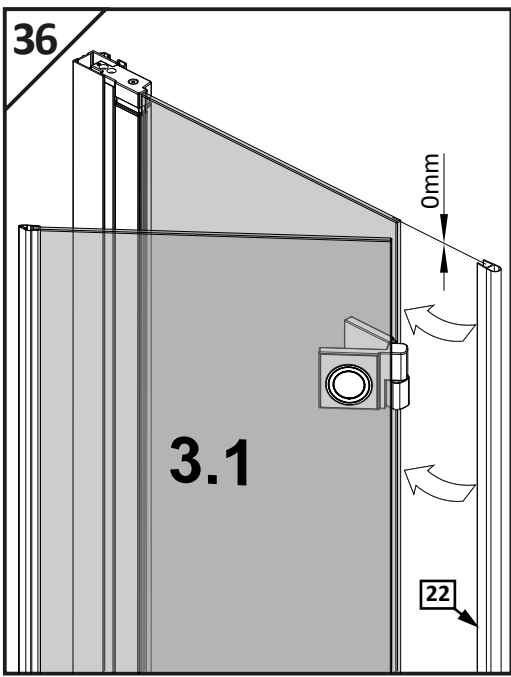
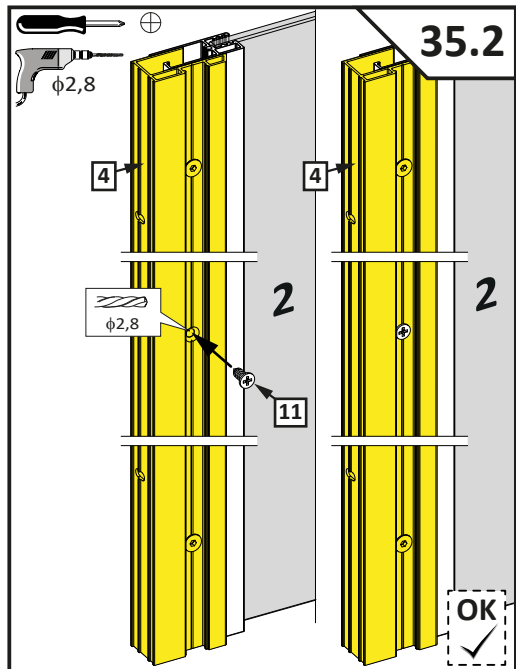
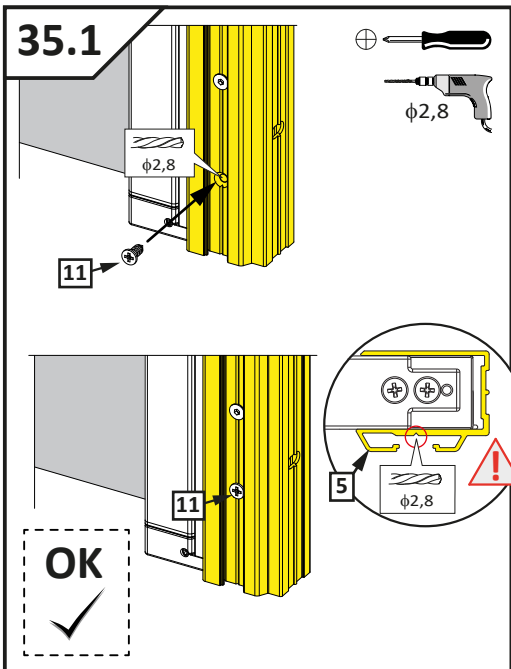

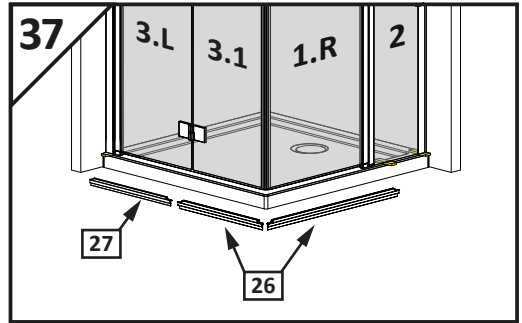
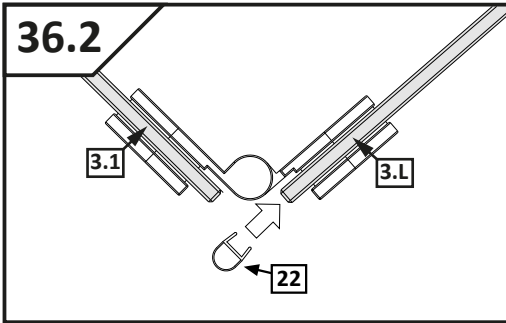



Montage mit Schwallschutzleiste
Installation with threshold profile

 → **37.1**

Montage ohne Schwallschutzleiste
Installation without threshold profile

 → **37.2**

37.1

37.2

x2

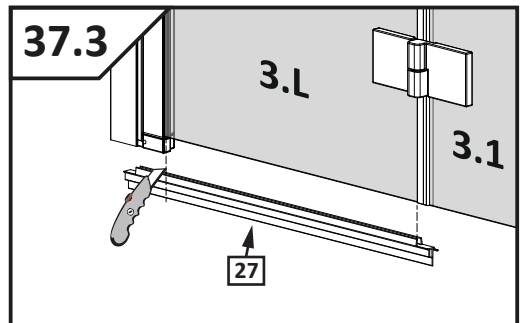
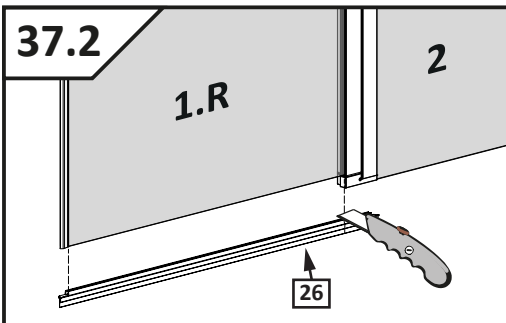

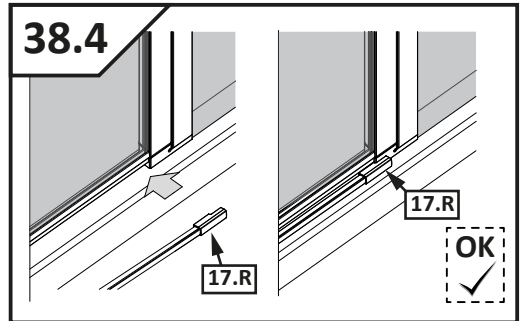
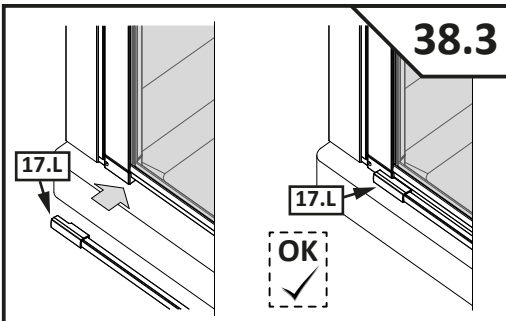
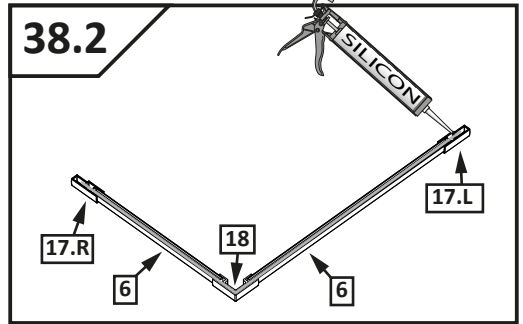
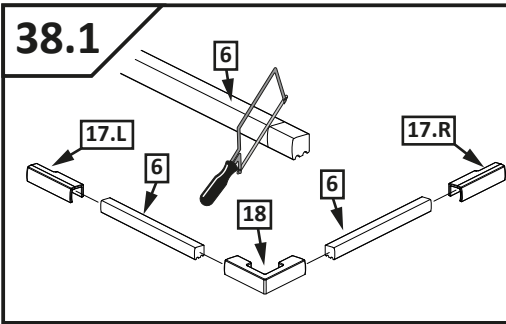
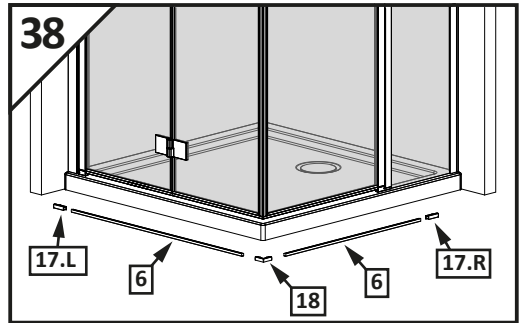
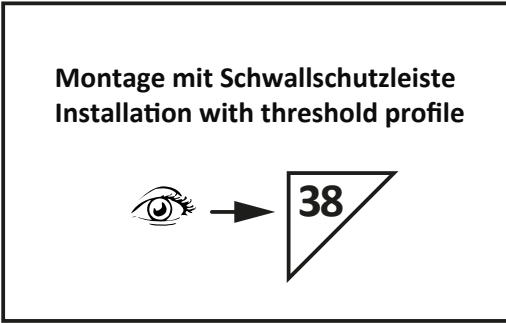
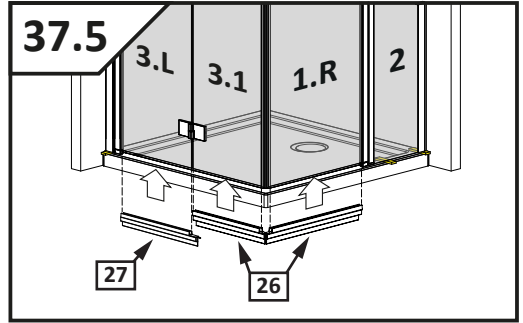
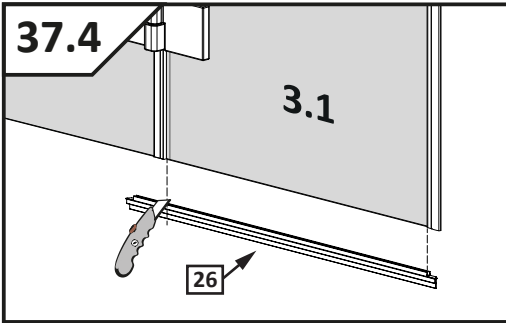

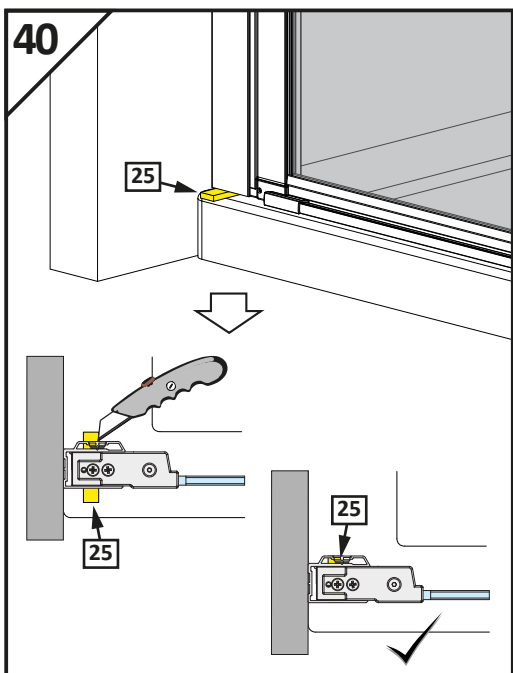
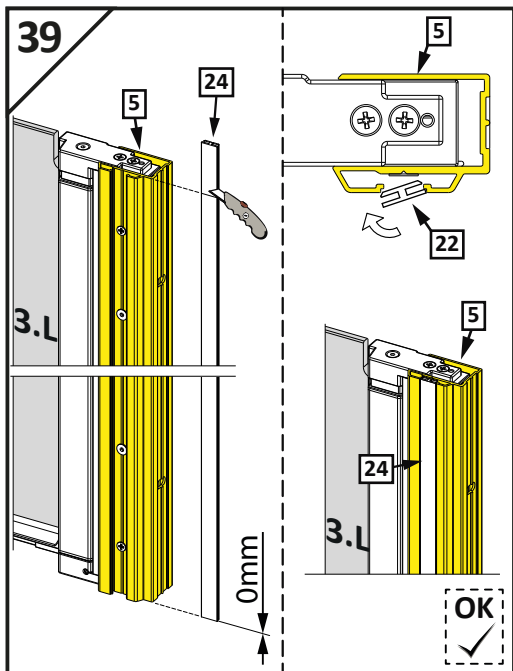
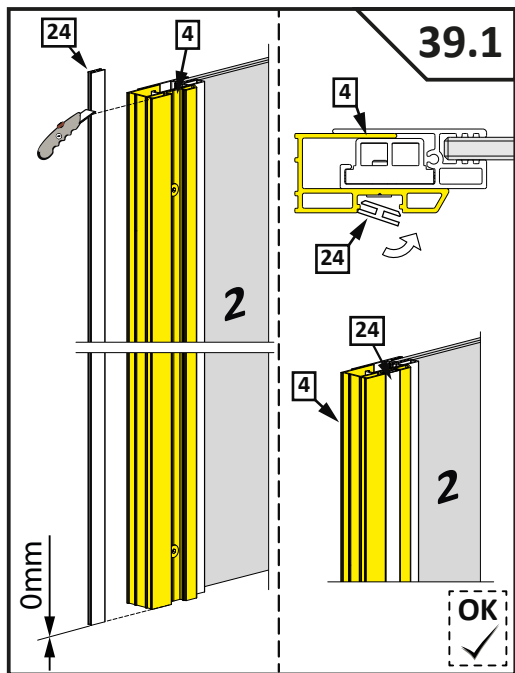
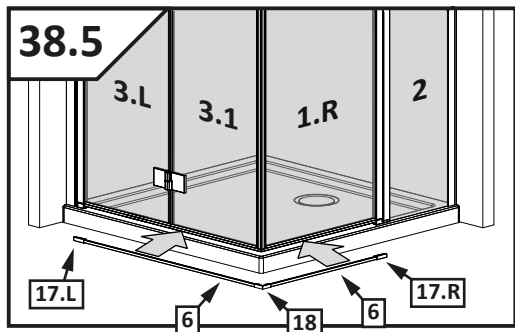

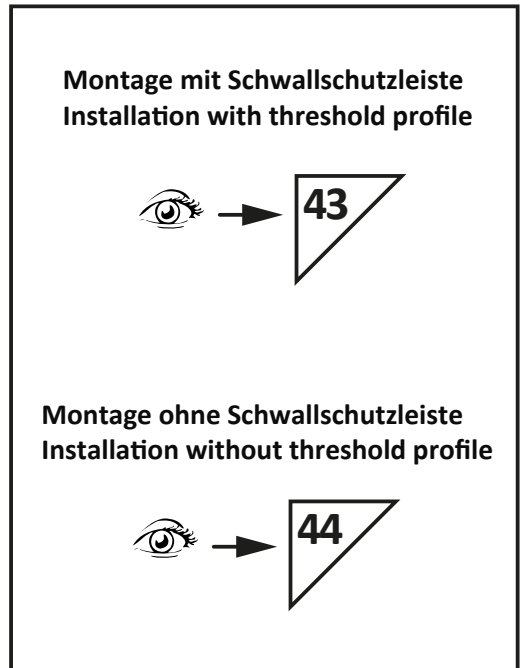
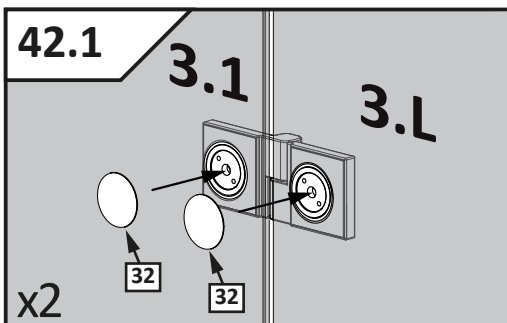
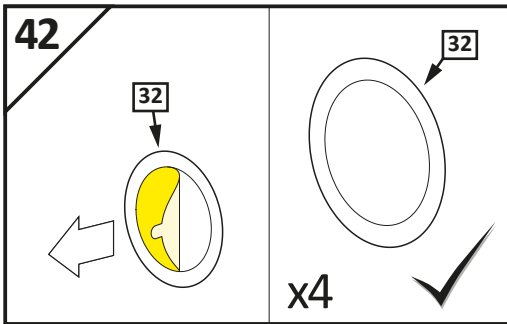
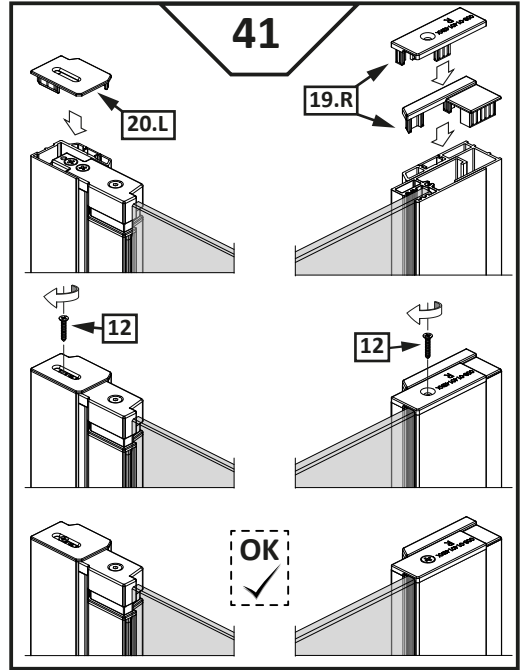
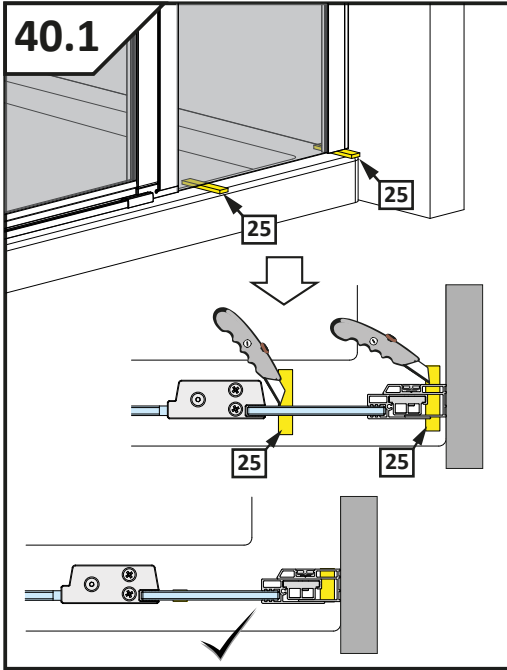

43

24h 

SILIKON

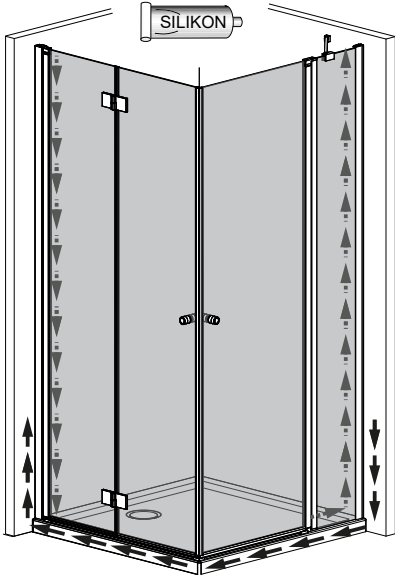

43.1

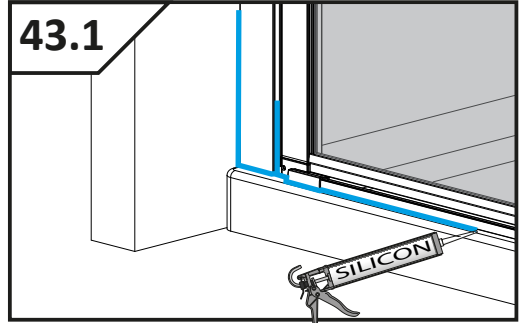

44

24h 

SILIKON

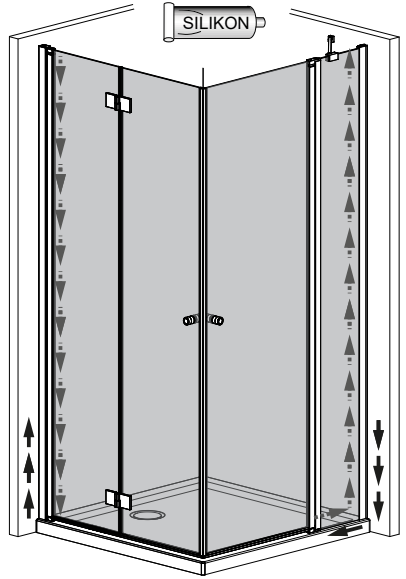

44.1

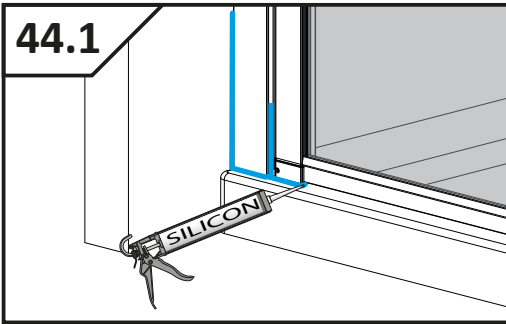



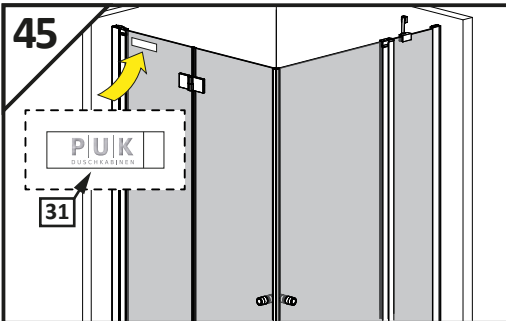





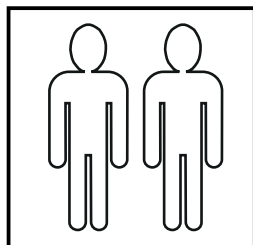
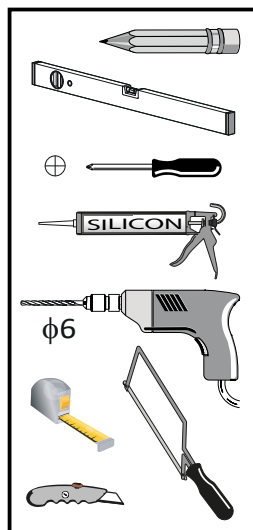



45



No. Nr	Bezeichnung Mark	Stück Pcs.
1.R		1
2.		1
3.1		1
3.L		1
4.		1
5.		1
6.		2
7.	φ6	9
8.	3.5x38 DIN 7981	4
9.	4.8x40 DIN 7981	4
10.	3.5x25 DIN 7982	2
11.	3.5x13 DIN 7982	3
12.	2.9x13 DIN 7982	2
13.	M4x10 DIN 7991	5
14.		2
15.	+ SW 2,5	1
16.R		1
17.L		1
17.R		1
18.		1
19.R		1
20.L		1

Montage mit Schallschutzleiste
Installation with threshold profile



No. Nr	Bezeichnung Mark	Stück Pcs.
21.		2
22.		1
23.		1
24.		2
25.		4
26.		2
27.		1
28.		3
29.1 29.2		1 1
30.		1
31.		1
32.		4

ODER K-1FTG+K-1PTG1F

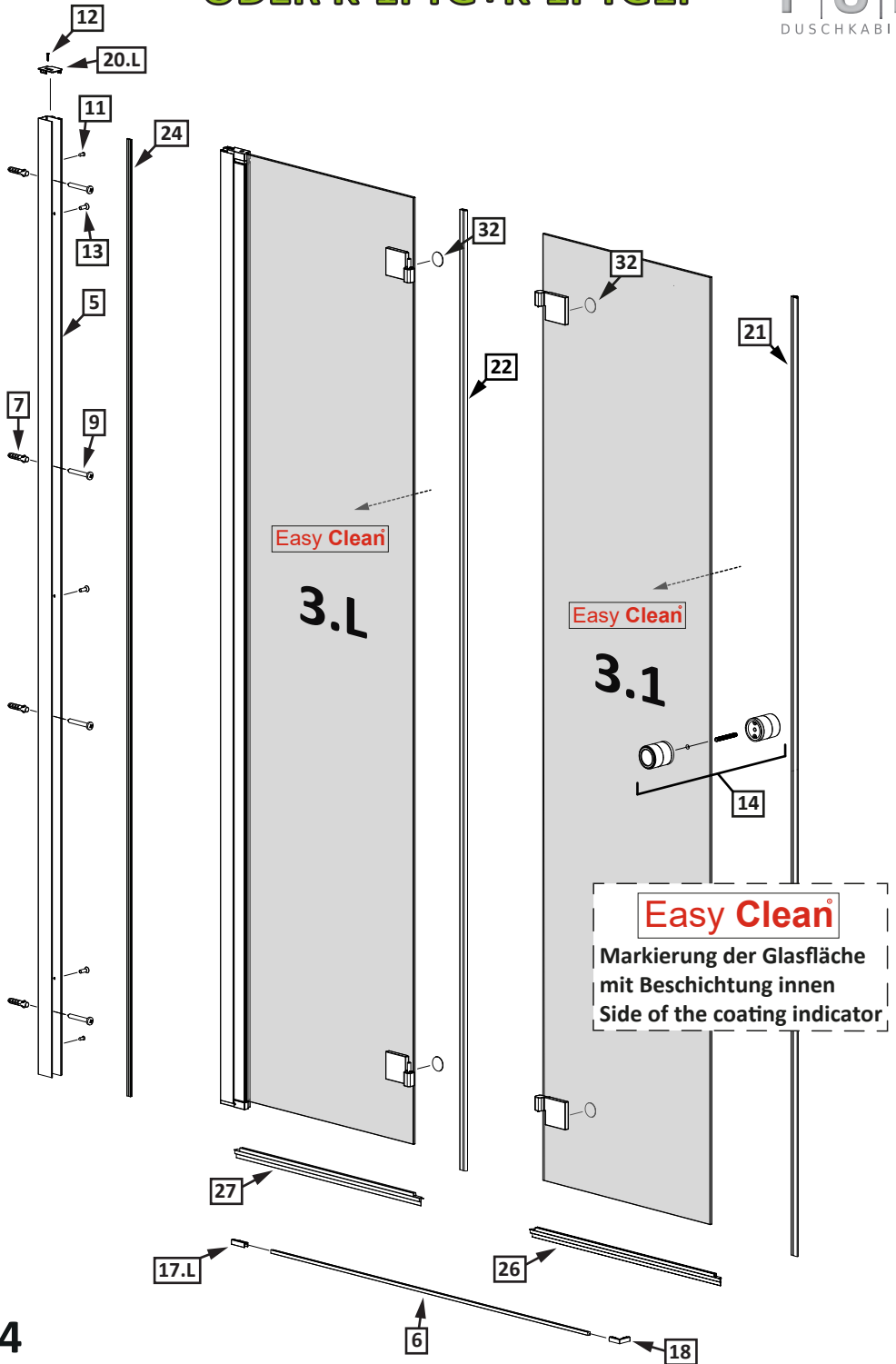

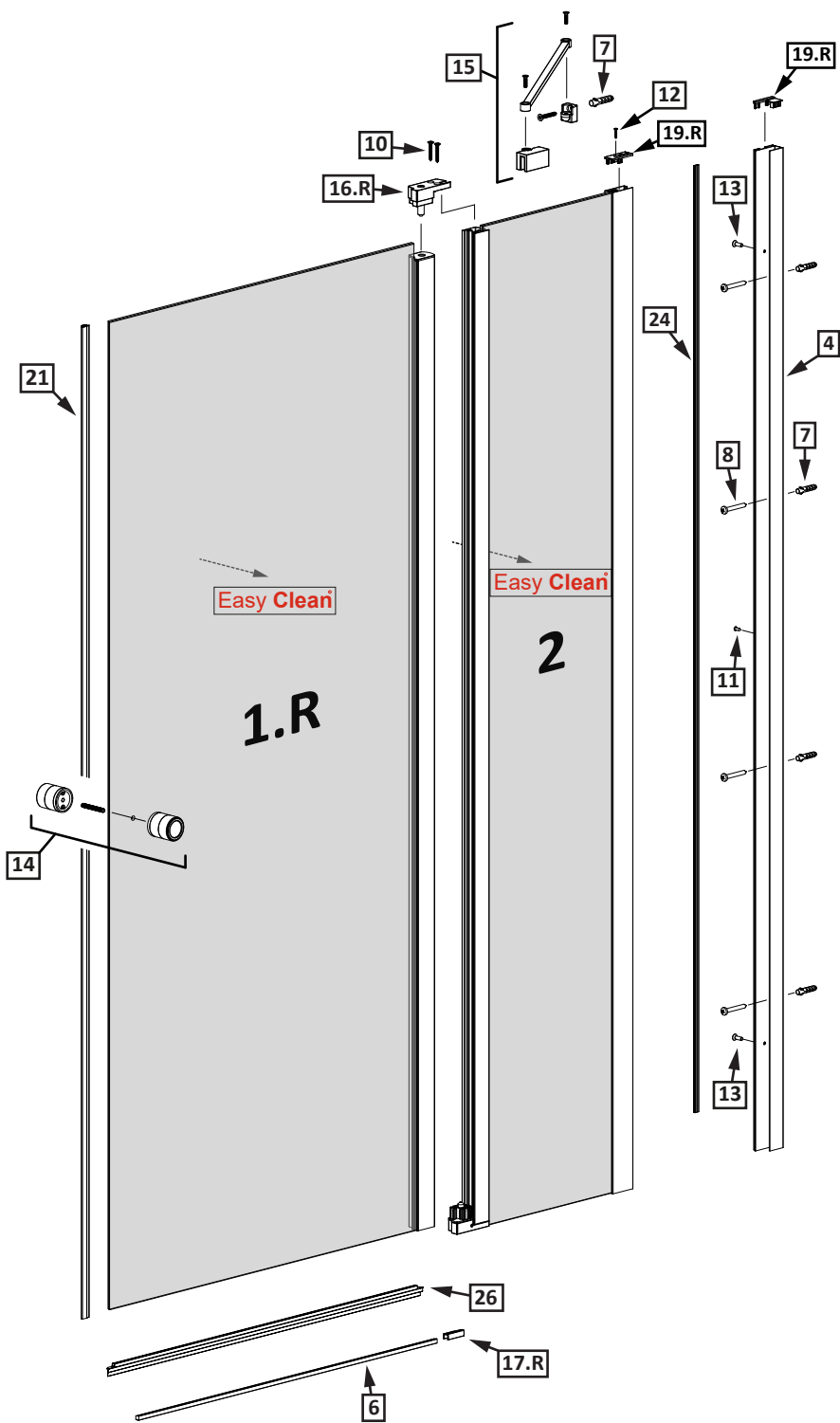

**Dichtigkeitsprüfung
nach DIN EN 14428**

Norm für
Funktionsanforderungen
und Prüfverfahren für
Duschabtrennungen

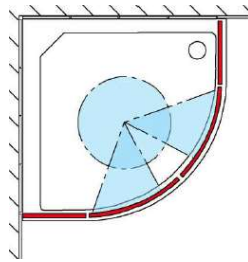

Runddusche

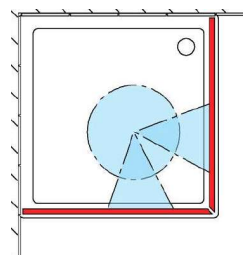

EckEinstieg

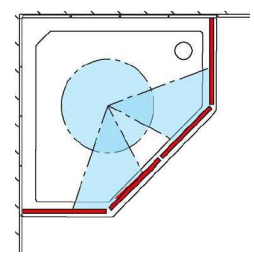

Fünfeckdusche

Geringe Mengen an Wasser dürfen austreten. Die Bildung größerer Pfützen ist nicht zulässig. Bei dem Test sollten 10-12ltr./min aus dem Duschkopf fließen. Beim Öffnen der Türen darf Wasser von den Türen ablaufen und auf den Boden tropfen.

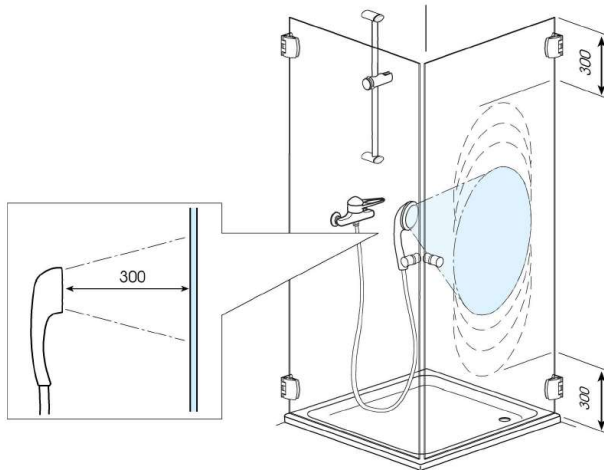

Dichtigkeitsprüfung in der
3D-Ansicht, alle Angaben
in mm.

Dichtigkeit von Duschabtrennungen

Dusche ist nicht gleich Dusche. Der Aufbau und das Design bestimmen maßgeblich die Spritzwasserdichtigkeit.

Alle PUK Duschabtrennungen erfüllen die Anforderungen der DIN EN 14428.

Bauartbedingt sind dabei Duschabtrennungen mit Profilen dichter als Duschabtrennungen ohne Profile. Wichtig ist, dass Sie Ihre Dusche nicht nur nach Design, sondern auch nach Duschgewohnheiten und der Situation am Aufbauort auswählen. Wir beraten Sie gerne.

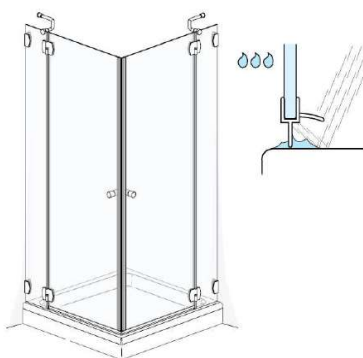

**Die rahmenlosen
Duschabtrennungen**

Nieste, Vispa und Trave RL bieten einen zufriedenstellenden Spritzschutz. Durch fehlende Profilleisten kann Wasser leichter nach außen dringen.

Die unübertroffene Eleganz, leichte Reinigung und hohe Exklusivität sprechen für diese Duschen.

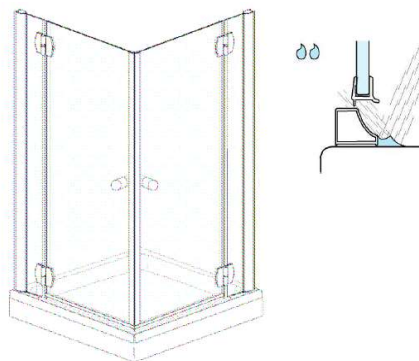

Die teilgerahmten Duschabtrennungen

Isen, Isar, Blies, Trave, Naab, Oder und Tanger bieten eine gute Dichtigkeit. Schlanke Profile, attraktive Griffe und Beschläge verleihen den Duschen ihre attraktive Leichtigkeit.

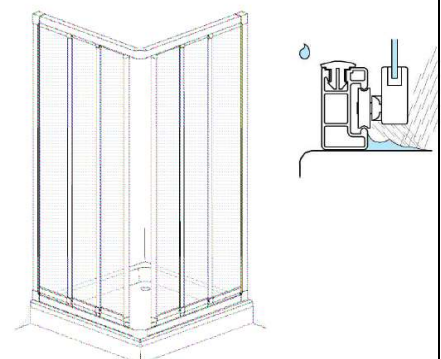

**Die vollgerahmte
Duschabtrennung**

Alvier weist die höchste Dichtigkeit auf. Je höher die Profile sind, umso unwahrscheinlicher ist es, dass Wasser nach außen fließt.

Garantie

Herzlichen Glückwunsch! Sie haben sich für eine Duschtrennung aus dem PUK-Programm und damit für ein Markenprodukt von höchster Qualität entschieden. Wir garantieren, dass unsere Produkte frei von Fabrikations- und Materialfehlern sind. Sollten trotz sorgfältiger Prüfung und hohen Qualitätsansprüchen dennoch Produktfehler auftreten, so werden wir nach eigener Wahl und auf eigene Kosten durch Reparatur, Austausch oder Neulieferung die Fehler beseitigen.

Garantieleistung und Umfang

Ein Austausch erfolgt durch kostenlose Lieferung und Einbau eines neuen Produktes gleicher Art und Güte. Falls ein fehlerhaftes Produkt nicht mehr hergestellt werden sollte, behalten wir uns vor, die Garantieleistungen auch durch ein gleichwertiges Produkt zu erfüllen.

Vorliegende Garantie wird für alle Produkte gewährt, die von Endkunden erworben wurden (Kaufbeleg). Diese Garantie ersetzt nicht und schränkt in keiner Weise die gesetzlichen Rechte gegenüber dem jeweiligen Händler oder gegenüber dem Hersteller des Produktes ein.

Der territoriale Geltungsbereich der Garantie ist auf das Gebiet der Bundesrepublik Deutschland, Republik Österreich und der Schweizerischen Eidgenossenschaft beschränkt.

Verschleißelemente, deren Dauerhaftigkeit sehr stark vom Nutzungsgrad und der erforderlichen Pflege abhängt, sind von der Garantie

ausgeschlossen (Dicht- und Magnetleisten, Rollen, Scharniere und andere bewegliche Teile).

Darüber hinaus gilt die Garantie nicht für:

- Silikonichtstoffe (Wartungsfugen)
- SmartClean® Beschichtung
- Geringe Farbabweichungen der Profile und Dekore
- Spiegegläser
- Ausstellungsprodukte

Geringe und nicht gehäuft auftretende Glaskratzer sowie Luftfeinschlüsse unter 0,5 mm sind zulässig. Maßgeblich für die Einschätzung ist die Kontrolle des Glases im Betrachtungsabstand von 1,5 m bei normalen Beleuchtungsverhältnissen.

Garantiezeiten

Die Garantiezeit beginnt ab Kaufdatum durch den Endkunden und beträgt:

- 10 Jahre für Duschtrennungen
- 5 Jahre für Mineralgusswannen

Die Garantiedauer erneuert sich nicht nach Gewährung von Garantieleistungen.

Garantieabwicklung

Im Garantiefall melden Sie sich bitte unverzüglich an uns oder Ihren Händler, postalisch oder an die E-Mail: service@puk-duschkabinen.de.

Für die Prüfung des Garantiefalls ist der Kaufnachweis mit Verkäuferdaten erforderlich.

Sobald ein Mangel entdeckt wird ist bis zur Überprüfung durch PUK jegliche weitere Nutzung des Produktes oder der Produktgruppe zu unterlassen.

Voraussetzungen der Garantie und Ausschlussgründe

Voraussetzung für die Inanspruchnahme der Garantie ist, dass die Produkte gemäß der Montageanleitung installiert worden sind. Die Montageanleitung wird zusammen mit den Produkten geliefert. Darüber hinaus stehen alle Montageanleitungen jederzeit zur Verfügung und zum Download unter:

<https://www.puk-duschkabinen.de/download/montageanleitung.en.de>

Voraussetzung ist auch, dass die durch PUK angegebenen Pflege- und Wartungsregeln eingehalten werden. Unsachgemäße Pflege, z.B. unter Verwendung ungeeigneter Reinigungsmittel oder Chemikalien, führt zum Ausschluss von Garantieansprüchen.

Das Entfernen der Komponenten, Verwenden von produktfremden Komponenten, zweckfremde Benutzung der Produkte sowie unsachgemäße Reparaturen und Änderungen am Produkt führen ebenfalls zum Ausschluss der Garantieansprüche.

Trotz sorgfältiger Untersuchung des Glases kann es vorkommen, dass kaum wahrnehmbare Nickel-Sulfid-Kristalle in der Glasschmelze eingeschlossen werden, aufgrund dessen das

Glas ohne sichtbare äußere Einwirkung zerbricht. Dieser seltene, dennoch nicht auszuschließende Spontanbruch begründet keinen Garantieanspruch.

Dichtigkeit: je nach Bauart werden unterschiedliche Dichtigkeitsstufen erreicht. Eine absolute Dichtigkeit ist konstruktionsbedingt nicht erreichbar.

Kosten für Service bei Nichteingreifen der Garantie

Bei ungerechtfertigter Inanspruchnahme der Garantie behalten wir uns vor, Kosten für Anfahrt und Arbeitszeit der Servicetechniker in Rechnung zu stellen.

Datenspeicherung für Garantiezwecke

Zum Zweck der Garantieprüfung und Abwicklung werden von uns die notwendigen personenbezogenen Daten gespeichert und verarbeitet.

Ihre PUK-Duschtrennung wurde heute montiert:

_____ Datum

_____ Name und Unterschrift des Monteurs/
der Montagefirma

PUK Duschkabinen wünscht Ihnen viel Freude mit Ihrer neuen Duschtrennung!